

flexident[®] senior

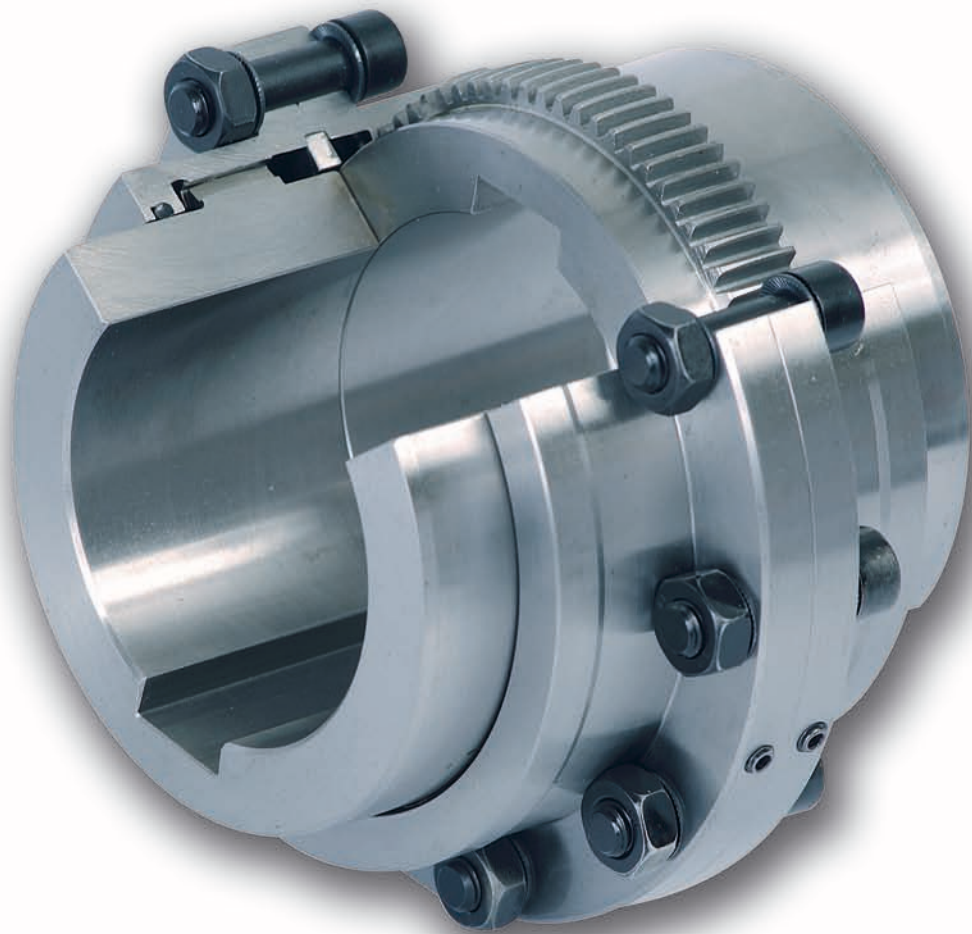

Fasteners class 12.9 allow torque transmission by friction.

Special gear teeth realized in order to increase the contact surface and to limit the superficial pressure.

Tightness with standard o-rings that guarantee the long life of couplings.

Special Shape of tooth in order to limit noise and vibrations interferences.

Gear Hub:
Bore hub capacity up to 800 mm optimization by finite elements.

Ring Gear:
Gear Teeth optimized by finite elements.

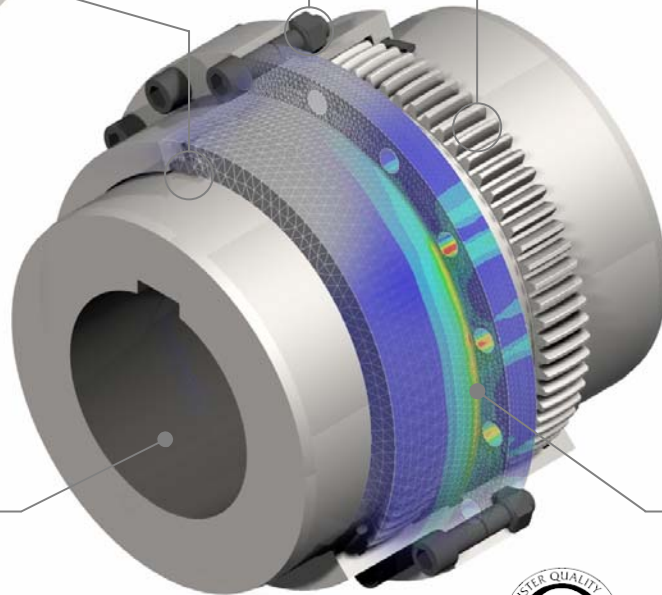
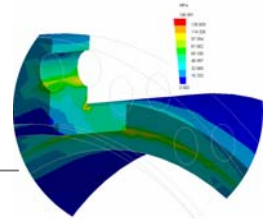

ISO 9001



Available according ATEX standards



High misalignment 1°30' for sizes 50 to 280
Misalignment 1° for sizes 310 up to 800



Working temperature



24 Sizes of entire steel coupling from 1 200 to 4 500 000 Nm.

Coupling Selection

A) Calculation of Corrected Torque: $\text{Corrected Torque} = \text{Absorbed Torque} \times \text{SF} = \frac{9550 \times P_{\text{Abs}} \text{ (kW)}}{\text{Speed (rpm)}} \times \text{SF}$

(Choice of the Service Factor SF – See following Data)

P Abs: Absorbed Power

B) Selection: Choose the coupling size that has a nominal torque equal or superior to the Corrected Torque.

C) Checking: Check the maximum boring and speed capacities.

| Service Factors Table | SF Δ | SF □ | SF O |
|--|---------|---------|------------|
| Uniform load, no shocks T max ≤ 1,5 T. Few start-up. - Generators; centrifugal pumps and compressors; small fans... | 1 | 1.12 | ** 1.25 |
| Uniform load, light shocks. T max < 1,8 T. Light and short overload. - Agitators and mixers for liquid or semi liquid; light textile machinery; rotary machines tools; light duty conveyors... | 1.12 | 1.25 | ** 1.40 |
| Non uniform load, moderate shocks. T max ≤ 2,2 T. Short time quite heavy overload. - Agitators or mixers for liquid and solid; elevators, overhead cranes; cranes in machining shops; cranes winches; card machine; dry can; loom; cloth finishing machine; extruder; hammer mill; tumbling mill; auxiliary drives for rolling mills; wire drawing machines... | 1.25 | 1.40 | ** 1.60 |
| Non uniform load, heavy shocks frequently. T max ≤ 3 T. High overload, reverse motion. - Compressors with flywheel; reciprocating; draw bench; cold mill ban; bury mixers; mixing mills; tire building machine; washers; barking drums; chippers; generators...; welder load... | 1.60 | 1.80 | ** 2 |
| Non uniform load, very heavy shocks, very frequently. T max from 3 to 3,5 T. Very high overload. Reverse motion - hot mill application; conveyors; live roll; shaker and reciprocating; gang raw (reciprocating); vibrating screen... | 2 | 2.25 | *** 2.5 |

Δ : Drive per motor Electric or turbine

□ : Drive per motor Hydraulic

O : Drive per motor multi cylinders internal combustion

** *Torsional analysis advised*

*** *Torsional analysis necessary*

Example of Selection

Application : Cement Kiln
Service Factor (Sf) = 1.25

Input Coupling

Input torque: 197 Nm
 Corrected torque: $197 \times 1.25 = 246.25$ Nm
 Diameter of auxiliary gearbox shaft: 45 mm
 Diameter of motor shaft: 55 mm
 Coupling selection: **S68**
 Page 6

Output Coupling

Output Torque: 27 707 Nm
 Corrected Torque:
 $27\ 707 \times 1.25 = 34\ 634$ Nm
 Ø Diameter of main gearbox shaft: 140 mm
 Ø Diameter of auxiliary gearbox shaft: 145 mm
 Coupling selection: **S170DB**
 Page 19

Electric motor of inching drive

Power = 30 kW
 Speed = 1450 rpm
 Application: Cement kiln
 Sf: 1.25 (according table page 3)

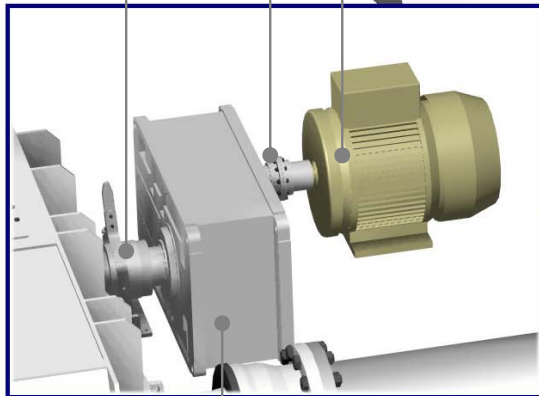

Inching drive reducer **ERmaster R4HC34**
 Reduction ratio: 140.23

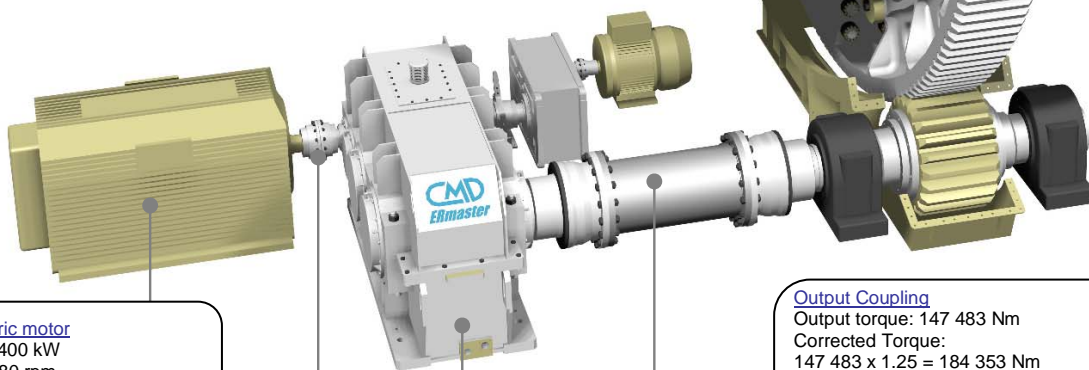

Main electric motor

Power = 2400 kW
 Speed = 980 rpm
 Application: Cement kiln
 Sf 1.25 (according table page 3)

Input coupling











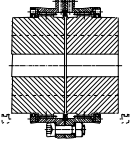

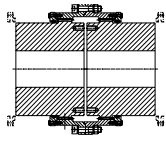
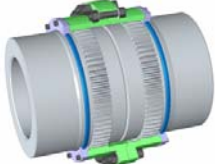
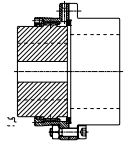
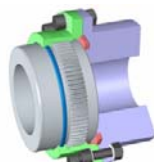
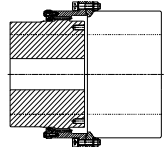
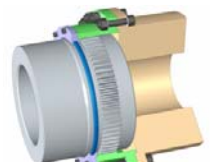
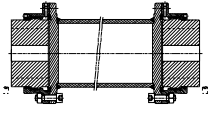
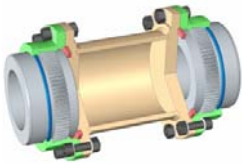
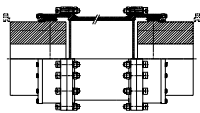

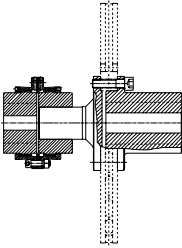
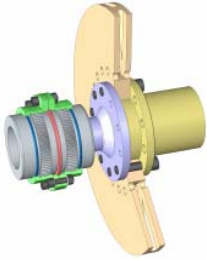
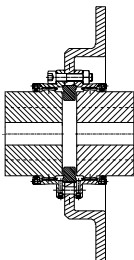
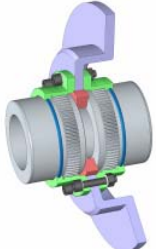
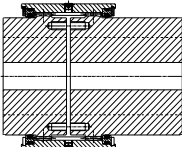

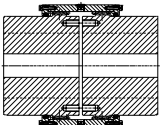
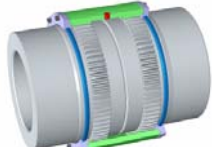
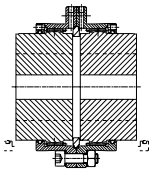
Input Torque: 23 387 Nm
 Corrected Torque:
 $23\ 387 \times 1.25 = 29\ 234$ Nm
 Diameter of gearbox shaft: 140 mm
 Diameter of motor shaft: 130 mm
 Coupling selection: **S150**
 Page 6

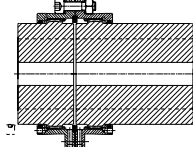
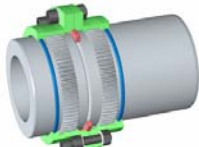
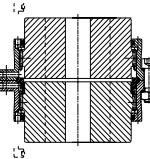
Output Coupling

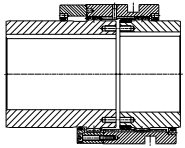
Output torque: 147 483 Nm
 Corrected Torque:
 $147\ 483 \times 1.25 = 184\ 353$ Nm
 Diameter of gearbox shaft: 250 mm
 Diameter of pinion shaft: 260 mm
 Distance between end shafts 5000 mm
 Coupling selection: **S280 E 5000**
 Page 10

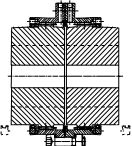
Main gearbox: **ERmaster R2HC50**
 Ratio: **6.306**

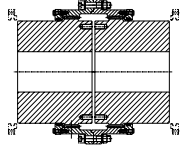
Standard models for general applications

| | | | | | |
|---|--|---|--|--|---|
|  | <p>Type S page 6 Nominal torque: 1 200 up to 190 000 Nm Max bore: 50 up to 280 mm</p> |  |  | <p>Type S page 7 Nominal torque: 255 000 up to 4 950 000 Nm Max bore: 310 up to 800 mm</p> |  |
|  | <p>Type S PA page 8 Nominal torque: 1 200 up to 190 000 Nm Max bore: 50 up to 280 mm</p> |  |  | <p>Type S PA page 9 Nominal torque: 255 000 up to 4 950 000 Nm Max bore: 310 up to 800 mm</p> |  |
|  | <p>Type S E page 10 Nominal torque: 1 200 up to 190 000 Nm Max bore: 50 up to 280 mm</p> |  |  | <p>Type S E page 11 Nominal torque: 255 000 up to 4 950 000 Nm Max bore: 310 up to 800 mm</p> |  |
|  | <p>Type S DF page 12 Application for brake disc Nominal torque: 3 000 up to 43 000 Nm Max bore: 68 up to 170 mm</p> |  |  | <p>Type S DFC page 13 Application for brake disc elbow Nominal torque: 1 200 up to 190 000 Nm Max bore: 50 up to 280 mm</p> |  |
|  | <p>Type S BM page 14 Solid cover Nominal torque: 1 200 up to 190 000 Nm Max bore: 50 up to 280 mm</p> |  |  | <p>Type S BM page 15 Solid cover Nominal torque: 255 000 up to 4 950 000 Nm Max bore: 310 up to 800 mm</p> |  |
|  | <p>Type S JL page 16 Limited end float Nominal torque: 1 200 up to 190 000 Nm Max bore: 50 up to 280 mm</p> |  |  | <p>Type S ML-ML2 page 17 Long hub Nominal torque: 1 200 up to 138 000 Nm Max bore: 50 up to 250 mm</p> |  |
|  | <p>Type S V page 18 Vertical mounting Nominal torque: 1 200 up to 190 000 Nm Max bore: 50 up to 280 mm</p> |  |  | <p>Type S DB page 19 Clutch system Nominal torque: 1 200 up to 138 000 Nm Max bore: 50 up to 250 mm</p> |  |
|  | <p>Type S R page 20 Reinforced Coupling Nominal torque: 1 855 up to 302 450 Nm Max bore: 50 up to 280 mm</p> |  |  | <p>Type S R page 21 Reinforced Coupling Nominal torque: 400 000 up to 7 780 000 Nm Max bore: 310 up to 800 mm</p> |  |

Type S – Horizontal working position

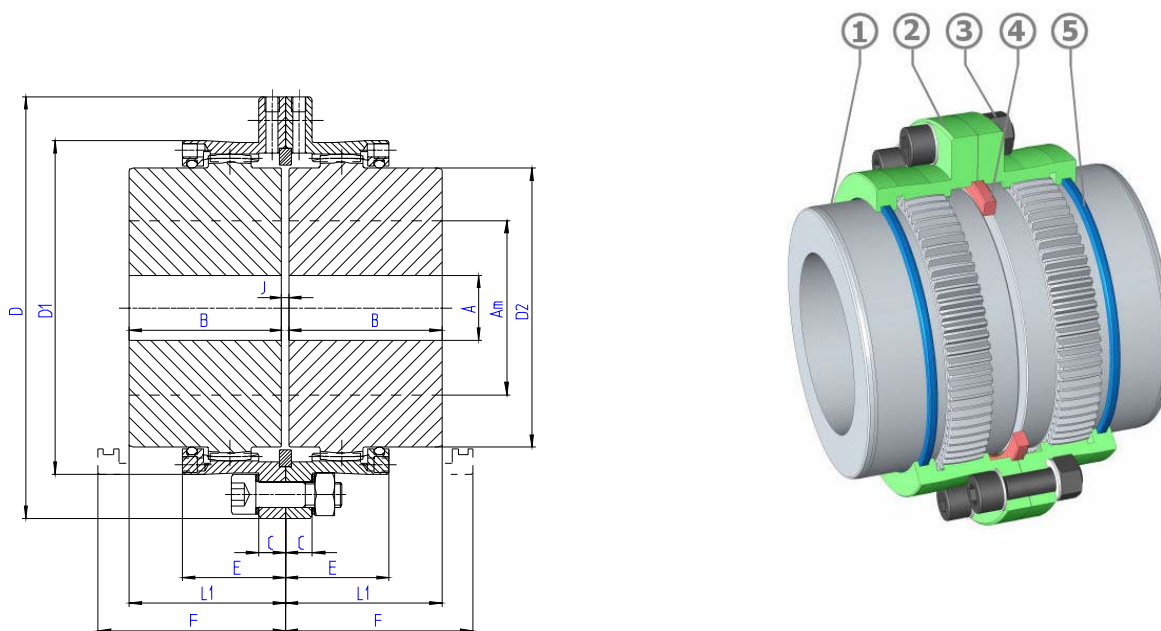

| Item | Designation |
|------|----------------|
| 1 | Gear Hub |
| 2 | Half cover |
| 3 | Screws & Bolts |
| 4 | Centering ring |
| 5 | Seal |

Example of designation: S80
SENIOR coupling size 80.

| Size | | 50 | 68 | 80 | 100 | 115 | 135 | 150 | 170 | 190 | 215 | 230 | 250 | 280 |
|-----------------------|------------------|-------|-------|-------|-------|-------|-------|-------|-------|-------|-------|--------|--------|--------|
| Nominal Torque | Nm | 1200 | 3000 | 5200 | 9000 | 13700 | 21300 | 29200 | 43000 | 60700 | 88200 | 105000 | 138000 | 190000 |
| Max Bore | Am* | 50 | 68 | 80 | 100 | 115 | 135 | 150 | 170 | 190 | 215 | 230 | 250 | 280 |
| | Am** | 46 | 63 | 75 | 92 | 106 | 125 | 140 | 160 | 175 | 200 | 210 | 230 | 250 |
| Rough bore | A | 18 | 18 | 26 | 35 | 35 | 58 | 68 | 83 | 98 | 108 | 118 | 128 | 128 |
| | B | 43 | 50 | 62 | 76 | 90 | 105 | 120 | 135 | 150 | 175 | 190 | 220 | 310 |
| | C | 10 | 10 | 11 | 11 | 14 | 18 | 20 | 20 | 24 | 24 | 30 | 30 | 30 |
| | D | 105 | 140 | 169 | 200 | 228 | 266 | 298 | 330 | 368 | 410 | 440 | 473 | 498 |
| | D1 | 83.6 | 112.6 | 134 | 164 | 188 | 219 | 245 | 277 | 309 | 351 | 374 | 407 | 432 |
| | D2 | 69.4 | 95 | 112 | 138 | 159 | 188 | 209 | 238 | 263 | 302 | 319 | 349 | 374 |
| | E | 30.5 | 36 | 42 | 52 | 63.5 | 74 | 82 | 91 | 100 | 110.5 | 122 | 135.5 | 139 |
| | J | 3 | 3 | 3 | 5 | 5 | 6 | 6 | 8 | 8 | 8 | 8 | 10 | 10 |
| | F | 55 | 63 | 75 | 93 | 112 | 130 | 145 | 163 | 180 | 205 | 220 | 253 | 343 |
| | L1 | 44.5 | 51.5 | 63.5 | 78.5 | 92.5 | 108 | 123 | 139 | 154 | 179 | 194 | 225 | 315 |
| Weight • | Kg | 3.7 | 7.7 | 13.2 | 23.5 | 36.7 | 59 | 84 | 119 | 164 | 243 | 300 | 406 | 616 |
| Moment of Inertia J • | Kgm ² | 0.004 | 0.012 | 0.030 | 0.079 | 0.166 | 0.368 | 0.649 | 1.141 | 1.962 | 3.63 | 5.18 | 8.08 | 13.07 |
| Max speed (rpm) | | 5400 | 4000 | 3400 | 2700 | 2400 | 2000 | 1800 | 1600 | 1500 | 1300 | 1200 | 1100 | 1000 |
| | y | 14000 | 10500 | 8900 | 7200 | 6300 | 5400 | 4800 | 4200 | 3800 | 3300 | 3100 | 2900 | 2700 |
| Weight of grease ∇ | Kg | 0.04 | 0.08 | 0.12 | 0.26 | 0.38 | 0.6 | 0.8 | 1 | 1.7 | 2.2 | 2.9 | 3.8 | 4 |

- * Bore with keyway according ISO R 773 or DIN 6885/1 standard
- ** Shrink fitting
- Solid hubs
- y Dynamically balanced
- ∇ Per coupling

Type S – Horizontal working position

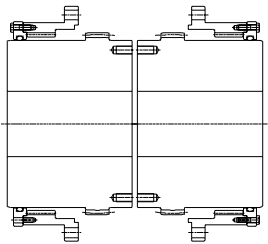
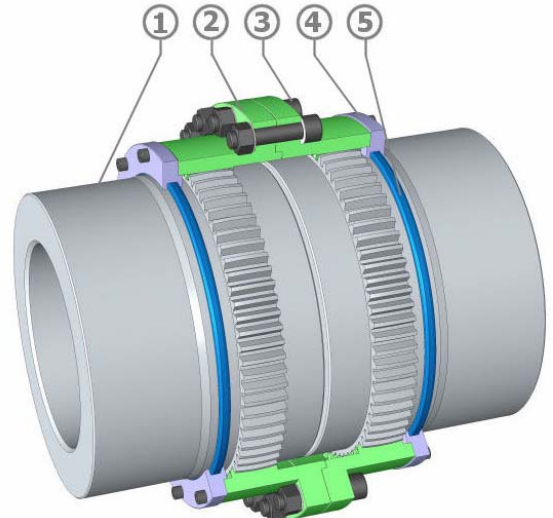
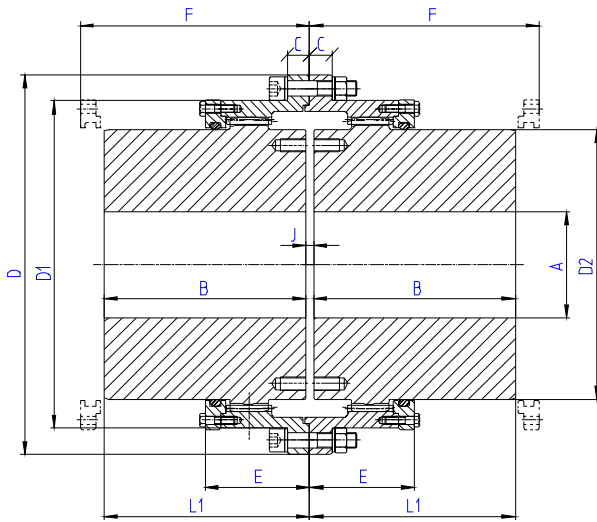

Inspection of the gear teeth is possible without having to remove the covers.

| Item | Designation |
|------|----------------|
| 1 | Gear Hub |
| 2 | Half cover |
| 3 | Screws & Bolts |
| 4 | Cover |
| 5 | Seal |

Example of designation: **S310**
SENIOR coupling size 310.

| Size | | 310 | 330 | 370 | 400 | 430 | 475 | 510 | 550 | 610 | 650 | 710 | 750 | 800 |
|----------------------|-------------|---------------|---------------|---------------|---------------|---------------|---------------|----------------|----------------|----------------|----------------|----------------|----------------|----------------|
| Nominal Torque | Nm | 255000 | 320000 | 410000 | 525000 | 670000 | 850000 | 1100000 | 1400000 | 1800000 | 2400000 | 3200000 | 3750000 | 4950000 |
| Max Bore | Am* | 310 | 330 | 370 | 400 | 430 | 475 | 510 | 550 | 610 | 650 | 710 | 750 | 800 |
| | Am** | 310 | 330 | 370 | 400 | 430 | 475 | 510 | 550 | 610 | 650 | 710 | 750 | 800 |
| Rough bore | A | 163 | 176 | 191 | 240 | 257 | 279 | 304 | 329 | 358 | 394 | 434 | 457 | 501 |
| | B | 310 | 330 | 350 | 370 | 430 | 480 | 505 | 515 | 535 | 575 | 610 | 650 | 700 |
| | C | 34 | 34 | 39 | 43 | 47 | 56 | 56 | 55 | 65 | 70 | 70 | 70 | 75 |
| | D | 575 | 608 | 676 | 735 | 793 | 940 | 990 | 1100 | 1225 | 1285 | 1395 | 1450 | 1555 |
| | D1 | 494 | 518 | 576 | 637 | 695 | 785 | 840 | 910 | 1000 | 1060 | 1170 | 1225 | 1295 |
| | D2 | 411 | 438 | 492 | 535 | 581 | 645 | 700 | 770 | 835 | 890 | 975 | 1030 | 1095 |
| | E | 155 | 166 | 166 | 190.5 | 204 | 212 | 250 | 250 | 270 | 305 | 335 | 345 | 385 |
| | J | 12 | 12 | 12 | 15 | 15 | 16 | 20 | 20 | 25 | 25 | 30 | 30 | 30 |
| | F | 350 | 370 | 395 | 420 | 478 | 550 | 570 | 575 | 600 | 640 | 680 | 720 | 770 |
| | L1 | 316 | 336 | 356 | 377.5 | 437.5 | 488 | 515 | 525 | 547.5 | 587.5 | 625 | 665 | 715 |
| | L2 | 316 | 336 | 356 | 377.5 | 437.5 | 488 | 515 | 525 | 547.5 | 587.5 | 625 | 665 | 715 |
| Weight • | Kg | 805 | 957 | 1261 | 1613 | 2191 | 3091 | 3825 | 4676 | 5833 | 7101 | 9025 | 10522 | 12927 |
| Moment of Inertia J• | Kgm² | 21.9 | 29.1 | 47.6 | 74.1 | 116.9 | 215.3 | 307.4 | 449.9 | 687.4 | 936 | 1419.4 | 1795.7 | 2512.1 |
| Max speed (rpm) | | 903 | 857 | 760 | 696 | 643 | 573 | 542 | 495 | 446 | 418 | 377 | 358 | 341 |
| | y | 2409 | 2285 | 2026 | 1857 | 1714 | 1528 | 1445 | 1320 | 1188 | 1114 | 1005 | 955 | 909 |
| Weight of grease ∇ | Kg | 6.2 | 6.6 | 7.9 | 11 | 13.5 | 18.2 | 22.3 | 23.8 | 30.5 | 37.1 | 48.5 | 62.2 | 73.5 |

- * Bore with keyway according ISO R 773 or DIN 6885/1 standard
- ** Shrink fitting
- Solid hubs
- y Dynamically balanced
- ∇ Per coupling

Type P-PA – Horizontal working position

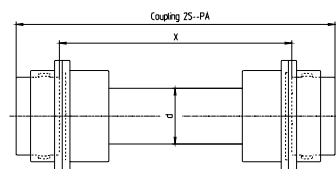
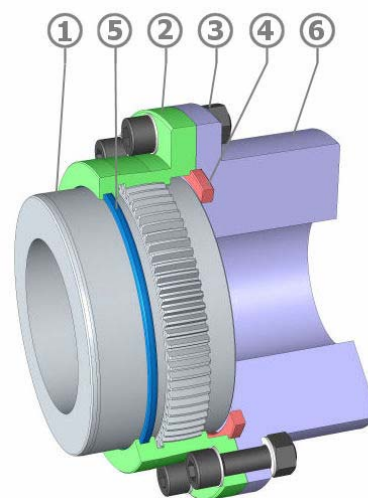
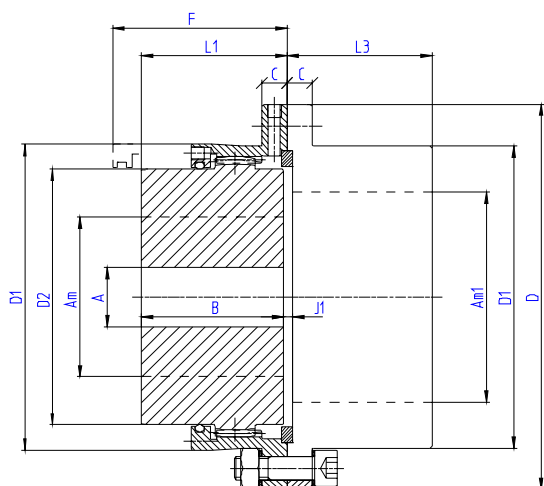

Ex Mounting

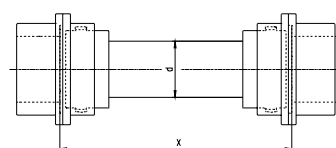

In Mounting

X: Distance between end shafts
X and d are defined according to the needs.

| Item | Designation |
|------|----------------|
| 1 | Gear Hub |
| 2 | Half cover |
| 3 | Screws & Bolts |
| 4 | Centering ring |
| 5 | Seal |
| 6 | Solid hub |

Example of designation: 2 S 80 PA 1000 In
SENIOR size 80, made of two half couplings **S80 P** joined by a spacer shaft for X = 1000 mm and a "In Mounting" (rigid hubs set up at the ends).
Ex Mounting (gear hubs set up at the ends)

| Size | | 50 | 68 | 80 | 100 | 115 | 135 | 150 | 170 | 190 | 215 | 230 | 250 | 280 |
|----------------------|------------------|-------|-------|-------|-------|-------|-------|-------|-------|-------|-------|--------|--------|--------|
| Nominal Torque | Nm | 1200 | 3000 | 5200 | 9000 | 13700 | 21300 | 29200 | 43000 | 60700 | 88200 | 105000 | 138000 | 190000 |
| Max Bore | Am* | 50 | 68 | 80 | 100 | 115 | 135 | 150 | 170 | 190 | 215 | 230 | 250 | 280 |
| | Am** | 46 | 63 | 75 | 92 | 106 | 125 | 140 | 160 | 175 | 200 | 210 | 230 | 250 |
| | Am1* | 60 | 80 | 95 | 115 | 135 | 155 | 175 | 190 | 220 | 250 | 265 | 290 | 310 |
| | Am1** | 55 | 75 | 85 | 110 | 125 | 145 | 160 | 180 | 205 | 230 | 250 | 270 | 280 |
| Rough bore | A | 18 | 18 | 26 | 35 | 35 | 58 | 68 | 83 | 98 | 108 | 118 | 128 | 128 |
| | B | 43 | 50 | 62 | 76 | 90 | 105 | 120 | 135 | 150 | 175 | 190 | 220 | 310 |
| | C | 10 | 10 | 11 | 11 | 14 | 18 | 20 | 20 | 24 | 24 | 30 | 30 | 30 |
| | D | 105 | 140 | 169 | 200 | 228 | 266 | 298 | 330 | 368 | 410 | 440 | 473 | 498 |
| | D1 | 83.6 | 112.6 | 134 | 164 | 188 | 219 | 245 | 277 | 309 | 351 | 374 | 407 | 432 |
| | D2 | 69.4 | 95 | 112 | 138 | 159 | 188 | 209 | 238 | 263 | 302 | 319 | 349 | 374 |
| | J1 | 3.5 | 4 | 4 | 5 | 6 | 7 | 8 | 9 | 10 | 10 | 11.5 | 12.5 | 12.5 |
| | F | 55 | 63 | 75 | 93 | 112 | 130 | 145 | 163 | 180 | 205 | 220 | 253 | 343 |
| | L1 | 44.5 | 51.5 | 63.5 | 78.5 | 92.5 | 108 | 123 | 139 | 154 | 179 | 194 | 225 | 315 |
| L3 | 45 | 52.5 | 64.5 | 78.5 | 93.5 | 109 | 125 | 140 | 156 | 181 | 197.5 | 227.5 | 317.5 | |
| Weight • | Kg | 4.5 | 9.1 | 15.6 | 27.6 | 43.5 | 70 | 99 | 139 | 193 | 281 | 352 | 472 | 712 |
| Moment of Inertia J• | Kgm ² | 0.005 | 0.017 | 0.041 | 0.106 | 0.220 | 0.484 | 0.861 | 1.493 | 2.6 | 4.74 | 6.85 | 10.6 | 17.16 |
| Max speed (rpm) | | 5400 | 4000 | 3400 | 2700 | 2400 | 2000 | 1800 | 1600 | 1500 | 1300 | 1200 | 1100 | 1000 |
| | y | 14000 | 10500 | 8900 | 7200 | 6300 | 5400 | 4800 | 4200 | 3800 | 3300 | 3100 | 2900 | 2700 |
| Weight of grease ▽ | Kg | 0.028 | 0.058 | 0.085 | 0.17 | 0.26 | 0.41 | 0.57 | 0.73 | 1.15 | 1.50 | 2.10 | 2.60 | 3 |

- * Bore with keyway according ISO R 773 or DIN 6885/1 standard
- ** Shrink fitting
- For couplings S..P - Solid hubs
- y Dynamically balanced
- ▽ Per coupling S..P

Type P-PA – Horizontal working position

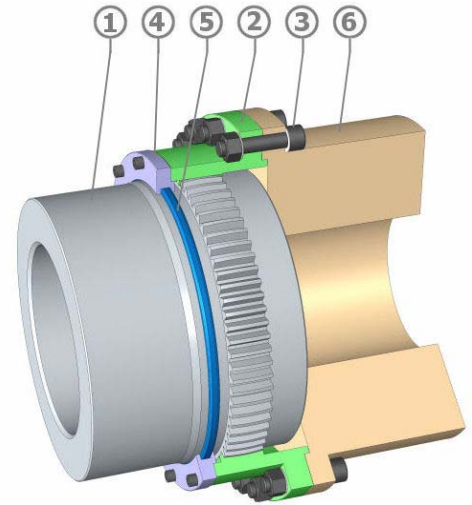
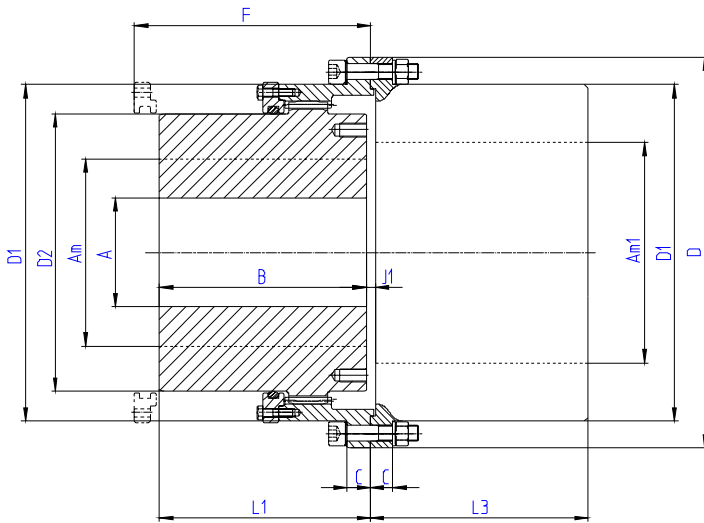

| Item | Designation |
|------|----------------|
| 1 | Gear Hub |
| 2 | Half cover |
| 3 | Screws & Bolts |
| 4 | Cover |
| 5 | Seal |
| 6 | Solid hub |

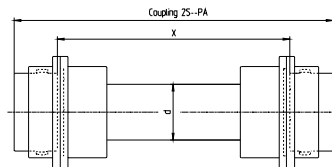

X: Distance between end shafts
X and d are defined according to the needs.

Ex Mounting

Inspection of the gear teeth is possible without having to remove the covers.

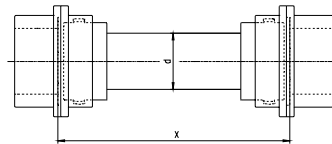

In Mounting

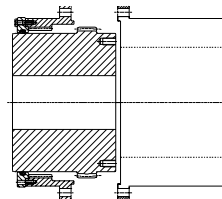

Example of designation: 2 S 310 PA 1000 In SENIOR size 310, made of two half couplings S310 P joined by a spacer shaft for X = 1000 and a "In Mounting".
In Mounting (rigid hubs set up at the ends).
Ex Mounting (gear hubs set up at the ends).

| Size | | 310 | 330 | 370 | 400 | 430 | 475 | 510 | 550 | 610 | 650 | 710 | 750 | 800 |
|----------------------|------------------|-------------|--------|--------|--------|--------|--------|---------|---------|---------|---------|---------|---------|---------|
| Nominal Torque | Nm | 255000 | 320000 | 410000 | 525000 | 670000 | 850000 | 1100000 | 1400000 | 1800000 | 2400000 | 3200000 | 3750000 | 4950000 |
| Max Bore | Am* | 310 | 330 | 370 | 400 | 430 | 475 | 510 | 550 | 610 | 650 | 710 | 750 | 800 |
| | Am** | 310 | 330 | 370 | 400 | 430 | 475 | 510 | 550 | 610 | 650 | 710 | 750 | 800 |
| | Am1 | Consult CMD | | | | | | | | | | | | |
| Rough bore | A | 163 | 176 | 191 | 240 | 257 | 279 | 304 | 329 | 358 | 394 | 434 | 457 | 501 |
| | B | 310 | 330 | 350 | 370 | 430 | 480 | 505 | 515 | 535 | 575 | 610 | 650 | 700 |
| | C | 34 | 34 | 39 | 43 | 47 | 56 | 56 | 55 | 65 | 70 | 70 | 70 | 75 |
| | D | 575 | 608 | 676 | 735 | 793 | 940 | 990 | 1100 | 1225 | 1285 | 1395 | 1450 | 1555 |
| | D1 | 494 | 518 | 576 | 637 | 695 | 785 | 840 | 910 | 1000 | 1060 | 1170 | 1225 | 1295 |
| | D2 | 411 | 438 | 492 | 535 | 581 | 645 | 700 | 770 | 835 | 890 | 975 | 1030 | 1095 |
| | J1 | 16 | 16 | 16 | 20 | 20 | 20 | 24 | 28 | 30 | 30 | 32 | 32 | 32 |
| | F | 350 | 370 | 395 | 420 | 478 | 550 | 570 | 575 | 600 | 640 | 680 | 720 | 770 |
| | L1 | 316 | 336 | 356 | 377.5 | 437.5 | 488 | 515 | 525 | 547.5 | 587.5 | 625 | 665 | 715 |
| L3 | 320 | 340 | 360 | 382 | 442 | 492 | 519 | 531 | 552 | 592 | 628 | 668 | 718 | |
| Weight • | Kg | 891.5 | 1049 | 1381.1 | 1774.4 | 2428.7 | 3476.1 | 4223.5 | 5118.7 | 6442.7 | 7794.4 | 9954.4 | 11582.7 | 14105.5 |
| Moment of Inertia J• | Kgm ² | 26.46 | 34.5 | 56.4 | 88.2 | 141.6 | 265.4 | 367.7 | 530.6 | 819 | 1106.4 | 1693.7 | 2142.2 | 2947.8 |
| Max speed (rpm) | | 903 | 857 | 760 | 696 | 643 | 573 | 542 | 495 | 446 | 418 | 377 | 358 | 341 |
| | y | 2409 | 2285 | 2026 | 1857 | 1714 | 1528 | 1445 | 1320 | 1188 | 1114 | 1005 | 955 | 909 |
| Weight of grease ∇ | Kg | 3.1 | 3.31 | 3.95 | 5.5 | 6.75 | 9.1 | 11.15 | 11.9 | 15.25 | 18.55 | 24.25 | 31 | 36.75 |

* Bore with keyway according ISO R 773 or DIN 6885/1 standard
 ** Shrink fitting
 • For couplings S..P - Solid hubs
 y Dynamically balanced
 ∇ Per coupling S..P

Type SE – Horizontal working position

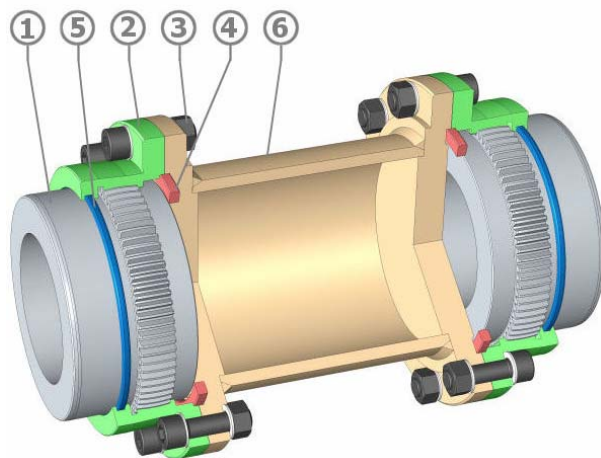
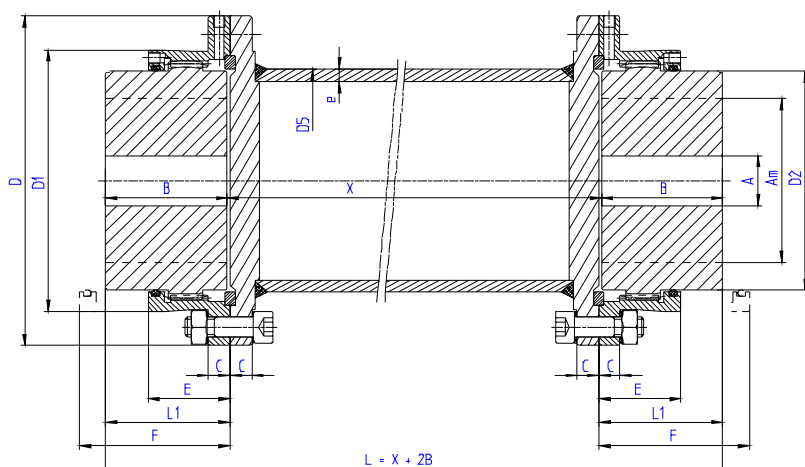

| Item | Designation |
|------|----------------|
| 1 | Gear Hub |
| 2 | Half cover |
| 3 | Screws & Bolts |
| 4 | Centering ring |
| 5 | Seal |
| 6 | Spacer |

Example of designation: S 80 E 1000

SENIOR size 80, made of two half couplings S80 joined by a tubular spacer with distance between end shafts X = 1000 mm.

| Size | | 50 | 68 | 80 | 100 | 115 | 135 | 150 | 170 | 190 | 215 | 230 | 250 | 280 |
|-----------------------|------------------|--------|--------|-------|--------|--------|--------|--------|-------|-------|-------|--------|--------|--------|
| Nominal Torque | Nm | 1200 | 3000 | 5200 | 9000 | 13700 | 21300 | 29200 | 43000 | 60700 | 88200 | 105000 | 138000 | 190000 |
| Max Bore | Am* | 50 | 68 | 80 | 100 | 115 | 135 | 150 | 170 | 190 | 215 | 230 | 250 | 280 |
| | Am** | 46 | 63 | 75 | 92 | 106 | 125 | 140 | 160 | 175 | 200 | 210 | 230 | 250 |
| Rough bore | A | 18 | 18 | 26 | 35 | 35 | 58 | 68 | 83 | 98 | 108 | 118 | 128 | 128 |
| | B | 43 | 50 | 62 | 76 | 90 | 105 | 120 | 135 | 150 | 175 | 190 | 220 | 310 |
| | C | 10 | 10 | 11 | 11 | 14 | 18 | 20 | 20 | 24 | 24 | 30 | 30 | 30 |
| | D | 105 | 140 | 169 | 200 | 228 | 266 | 298 | 330 | 368 | 410 | 440 | 473 | 498 |
| | D1 | 83.6 | 112.6 | 134 | 164 | 188 | 219 | 245 | 277 | 309 | 351 | 374 | 407 | 432 |
| | D2 | 69.4 | 95 | 112 | 138 | 159 | 188 | 209 | 238 | 263 | 302 | 319 | 349 | 374 |
| | E | 30.5 | 36 | 42 | 52 | 63.5 | 74 | 82 | 91 | 100 | 110.5 | 122 | 135.5 | 139 |
| | D5 | 70 | 101.6 | 114.3 | 139.7 | 168.3 | 193.7 | 203 | 244.5 | 273 | 323.9 | 355.6 | 368 | 406.4 |
| | e | 4 | 5 | 6.3 | 8 | 7.1 | 10 | 12.5 | 12.5 | 12.5 | 12.5 | 12.5 | 16 | 16 |
| | F | 55 | 63 | 75 | 93 | 112 | 130 | 145 | 163 | 180 | 205 | 220 | 253 | 343 |
| | L1 | 44.5 | 51.5 | 63.5 | 78.5 | 92.5 | 108 | 123 | 139 | 154 | 179 | 194 | 225 | 315 |
| Weight • | Kg | 11.6 | 22.1 | 34 | 55 | 75 | 121 | 165 | 218 | 285 | 390 | 480 | 628 | 870 |
| Moment of Inertia J• | Kgm ² | 0.013 | 0.045 | 0.093 | 0.218 | 0.407 | 0.883 | 1.42 | 2.45 | 4 | 7 | 10 | 15.6 | 21.8 |
| Weight Δ | Kg | 0.65 | 1.19 | 1.67 | 2.59 | 2.81 | 4.5 | 5.9 | 7.1 | 8 | 9.6 | 10.5 | 13.8 | 15.3 |
| Moment of Inertia J Δ | Kgm ² | 0.0007 | 0.0028 | 0.005 | 0.0113 | 0.0183 | 0.0383 | 0.0533 | 0.096 | 0.136 | 0.232 | 0.31 | 0.43 | 0.59 |
| Weight of grease ▽ | Kg | 0.04 | 0.08 | 0.12 | 0.26 | 0.38 | 0.6 | 0.8 | 1 | 1.70 | 2.20 | 2.90 | 3.80 | 4 |

- * Bore with keyway according ISO R 773 or DIN 6885/1 standard
- ** Shrink fitting
- For couplings with spacer X=1000 mm: Solid hubs
- Δ Correction for variation X=100 mm
- ▽ Per coupling

Type SE – Horizontal working position

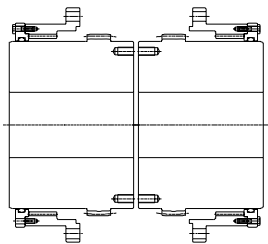
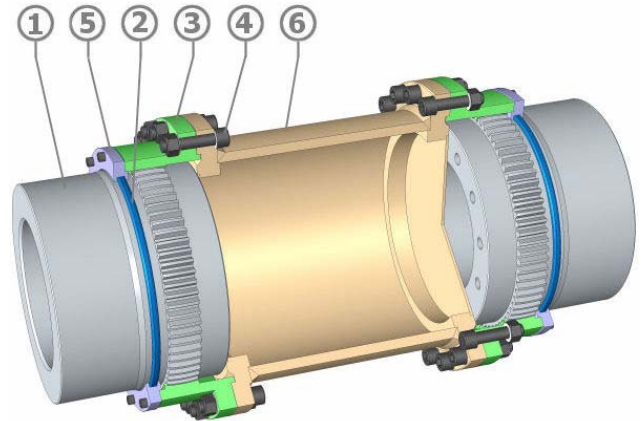
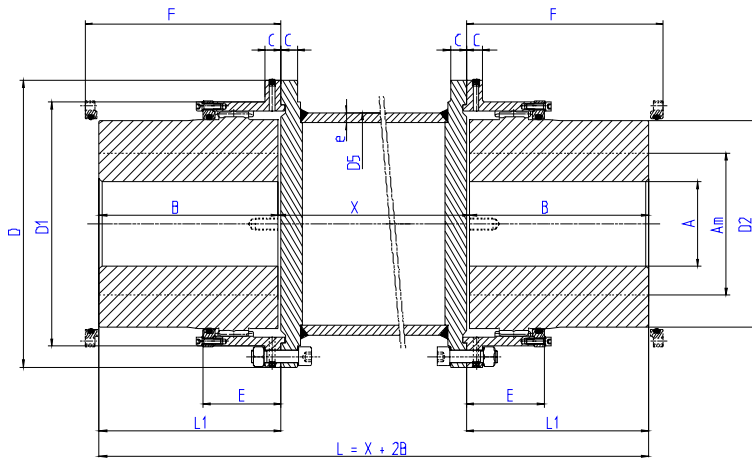

Inspection of the gear teeth is possible without having to remove the covers.

| Item | Designation |
|------|----------------|
| 1 | Gear Hub |
| 2 | Seal |
| 3 | Half cover |
| 4 | Screws & Bolts |
| 5 | Cover |
| 6 | Spacer |

Example of designation: S 310 E 1000

SENIOR size 310, made of two half couplings S310 joined by a tubular spacer with distance between end shafts $X = 1000$ mm.

| Size | | 310 | 330 | 370 | 400 | 430 | 475 | 510 | 550 | 610 | 650 | 710 | 750 | 800 | |
|----------------|-----------------------|------------------|--------|--------|--------|--------|--------|---------|---------|---------|---------|---------|---------|---------|---------|
| Nominal Torque | Nm | 255000 | 320000 | 410000 | 525000 | 670000 | 850000 | 1100000 | 1400000 | 1800000 | 2400000 | 3200000 | 3750000 | 4950000 | |
| Max Bore | Am* | 310 | 330 | 370 | 400 | 430 | 475 | 510 | 550 | 610 | 650 | 710 | 750 | 800 | |
| | Am** | 310 | 330 | 370 | 400 | 430 | 475 | 510 | 550 | 610 | 650 | 710 | 750 | 800 | |
| Rough bore | A | 163 | 176 | 191 | 240 | 257 | 279 | 304 | 329 | 358 | 394 | 434 | 457 | 501 | |
| | B | 310 | 330 | 350 | 370 | 430 | 480 | 505 | 515 | 535 | 575 | 610 | 650 | 700 | |
| | C | 34 | 34 | 39 | 43 | 47 | 56 | 56 | 55 | 65 | 70 | 70 | 70 | 75 | |
| | D | 575 | 608 | 676 | 735 | 793 | 940 | 990 | 1100 | 1225 | 1285 | 1395 | 1450 | 1555 | |
| | D1 | 494 | 518 | 576 | 637 | 695 | 785 | 840 | 910 | 1000 | 1060 | 1170 | 1225 | 1295 | |
| | D2 | 411 | 438 | 492 | 535 | 581 | 645 | 700 | 770 | 835 | 890 | 975 | 1030 | 1095 | |
| | D5 | 470 | 470 | 559 | 610 | 665 | 760 | 815 | 880 | 990 | 1030 | 1130 | 1185 | 1255 | |
| | e | 20 | 20 | 20 | 20 | 25 | 25 | 25 | 30 | 30 | 40 | 45 | 45 | 55 | |
| | E | 155 | 166 | 166 | 190.5 | 204 | 212 | 250 | 250 | 270 | 305 | 335 | 345 | 385 | |
| | F | 350 | 370 | 395 | 420 | 478 | 550 | 570 | 575 | 600 | 640 | 680 | 720 | 770 | |
| | L1 | 316 | 336 | 356 | 377.5 | 437.5 | 488 | 515 | 525 | 547.5 | 587.5 | 625 | 665 | 715 | |
| | Weight • | Kg | 1185 | 1348 | 1770 | 2223 | 2983 | 4180 | 5017 | 6176 | 7841 | 9588 | 12001 | 13723 | 16841 |
| | Moment of Inertia J • | Kgm ² | 38.26 | 46.76 | 78.47 | 117.5 | 183.14 | 337.78 | 457.43 | 676.75 | 1059.44 | 1437.35 | 2131.3 | 2626.1 | 3667.77 |
| | Weight △ | Kg | 22.1 | 22.1 | 26.5 | 29 | 39 | 49.4 | 57.7 | 62.1 | 69.8 | 86.7 | 107.7 | 127.9 | 151.3 |
| | Moment of Inertia J △ | Kgm ² | 1.1 | 1.1 | 1.9 | 2.5 | 3.9 | 5.6 | 8.9 | 11.1 | 15.7 | 22.0 | 32.4 | 42.9 | 57.5 |
| | Weight of grease ▽ | Kg | 6.2 | 6.62 | 7.9 | 11 | 13.5 | 18.2 | 22.3 | 23.8 | 30.5 | 37.1 | 48.5 | 62.15 | 73.5 |

- * Bore with keyway according ISO R 773 or DIN 6885/1 standard
- ** Shrink fitting
- For couplings with spacer $X=1000$ mm: Solid hubs
- △ Correction for variation $X=100$ mm
- ▽ Per coupling

Type SDF – Horizontal working position

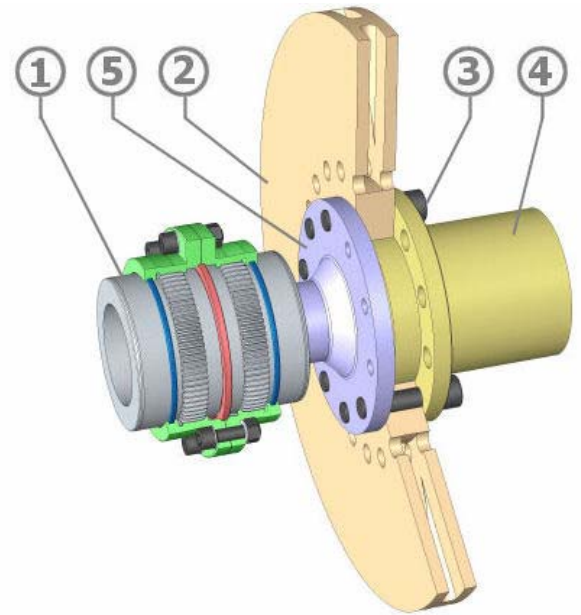
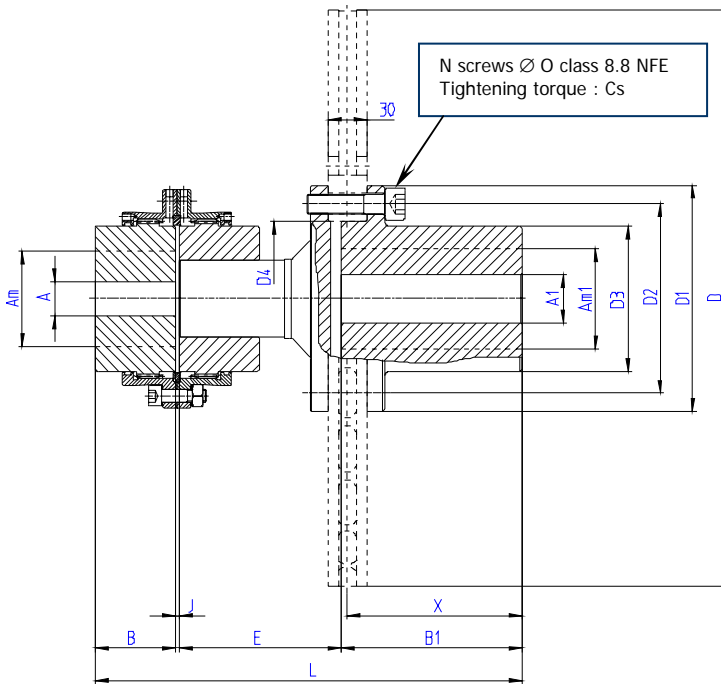

| Item | Designation |
|------|-------------------|
| 1 | Coupling Senior S |
| 2 | Brake disc |
| 3 | Screws & Bolts |
| 4 | Solid hub |
| 5 | Spacer |

Π : max speed allowed by the disc according the manufacturer. For higher speed, please consult us.

| DISC AND SOLID HUB | | | | | | | | | | | | | |
|--------------------|------------------------|----|------|-------|-----|-----|-----|-----|-----|----|-----|----------|-----|
| D | Π Min ⁻¹ | A1 | Am1* | Am1** | B1 | D1 | D2 | D3 | D4 | N | O | Cs Nm | X |
| 315 | 3000 | / | 55 | 50 | 107 | 124 | 105 | 82 | 85 | 9 | M10 | 49 | 102 |
| 355 | 2700 | / | 70 | 60 | 107 | 145 | 125 | 100 | 105 | 9 | M12 | 86 | 102 |
| 395 | 2400 | / | 75 | 70 | 107 | 165 | 140 | 112 | 115 | 9 | M14 | 135 | 102 |
| 445 | 2100 | / | 80 | 70 | 140 | 175 | 146 | 112 | 120 | 12 | M16 | 210 | 135 |
| 495 | 1900 | 30 | 110 | 100 | 140 | 218 | 190 | 155 | 160 | 12 | M18 | 290 | 135 |
| 550 | 1800 | 30 | 110 | 100 | 140 | 218 | 190 | 155 | 160 | 12 | M18 | 290 | 135 |
| 625 | 1500 | 30 | 120 | 105 | 140 | 238 | 205 | 168 | 170 | 12 | M20 | 410 | 135 |
| 705 | 1300 | 30 | 135 | 120 | 140 | 268 | 230 | 190 | 195 | 12 | M22 | 550 | 135 |
| 795 | 1200 | 30 | 150 | 135 | 140 | 300 | 260 | 216 | 220 | 12 | M24 | 710 | 135 |

Example of designation: **S80 DF 550**
SENIOR coupling size 80 with a 550 diameter brake disc.

| SIZE | | 68 | | | | 80 | | | | 100 | | | | 115 | | | | 135 | | | | 150 | | | | 170 | |
|-----------------------|------------------|------|------|------|------|------|------|------|------|------|------|------|------|------|------|------|------|-------|-------|-------|-------|-------|-------|-------|-------|-------|-------|
| | | | | | | | | | | | | | | | | | | | | | | | | | | | |
| Disc diameter | | 315 | 355 | 395 | 445 | 395 | 445 | 495 | 550 | 445 | 495 | 550 | 625 | 495 | 550 | 625 | 705 | 625 | 705 | 795 | 625 | 705 | 795 | 705 | 795 | 705 | 795 |
| Peak torque Max | Nm | 1500 | 2200 | 2200 | 2200 | 2200 | 3800 | 3800 | 3800 | 6000 | 6000 | 6000 | 6000 | 9400 | 9400 | 9400 | 9400 | 13800 | 13800 | 13800 | 20700 | 25300 | 25300 | 29200 | 36700 | | |
| Rough bore | A | 18 | | | | 26 | | | | 35 | | | | 35 | | | | 58 | | | | 68 | | 83 | | | |
| Max Bore | Am* | 68 | | | | 80 | | | | 100 | | | | 115 | | | | 135 | | | | 150 | | 170 | | | |
| | Am** | 63 | | | | 75 | | | | 92 | | | | 106 | | | | 125 | | | | 140 | | 160 | | | |
| | B | 50 | | | | 62 | | | | 76 | | | | 90 | | | | 105 | | | | 120 | | 135 | | | |
| | J | 3 | | | | 3 | | | | 5 | | | | 5 | | | | 6 | | | | 6 | | 8 | | | |
| | E | 117 | 117 | 117 | 117 | 117 | 130 | 145 | 145 | 145 | 164 | 164 | 164 | 180 | 180 | 180 | 180 | 196 | 196 | 196 | 223 | 223 | 223 | 238 | 238 | 238 | 238 |
| | L | 274 | 274 | 274 | 307 | 286 | 332 | 347 | 347 | 361 | 380 | 380 | 380 | 410 | 410 | 410 | 410 | 441 | 441 | 441 | 483 | 483 | 483 | 513 | 513 | 513 | 513 |
| Weight • | Kg | 15 | 18 | 20.5 | 24 | 26 | 30 | 45 | 45 | 40 | 56 | 56 | 63 | 71 | 71 | 77 | 87 | 99 | 110 | 123 | 127 | 137 | 150 | 173 | 185 | 173 | 185 |
| Moment of Inertia J • | Kgm ² | 0.02 | 0.03 | 0.04 | 0.05 | 0.06 | 0.07 | 0.16 | 0.16 | 0.12 | 0.21 | 0.21 | 0.27 | 0.3 | 0.3 | 0.36 | 0.48 | 0.559 | 0.68 | 0.862 | 0.846 | 0.965 | 1.148 | 1.463 | 1.642 | 1.463 | 1.642 |
| Weight of grease | Kg | 0.08 | | | | 0.12 | | | | 0.26 | | | | 0.38 | | | | 0.60 | | | | 0.80 | | 1 | | | |

* Bore with keyway according ISO R 773 or DIN 6885/1 standard
 ** Shrink fitting
 • Solid hubs
 y Dynamically balanced
 ∇ Per coupling

Check that the max peak torque of the coupling is higher than the peak torque of the installation

Type SDFC – Horizontal working position

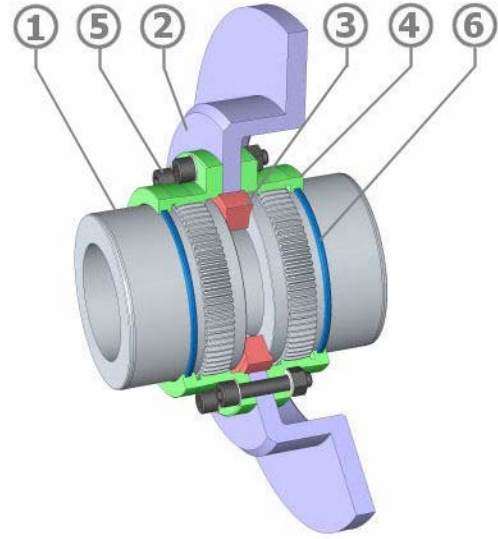
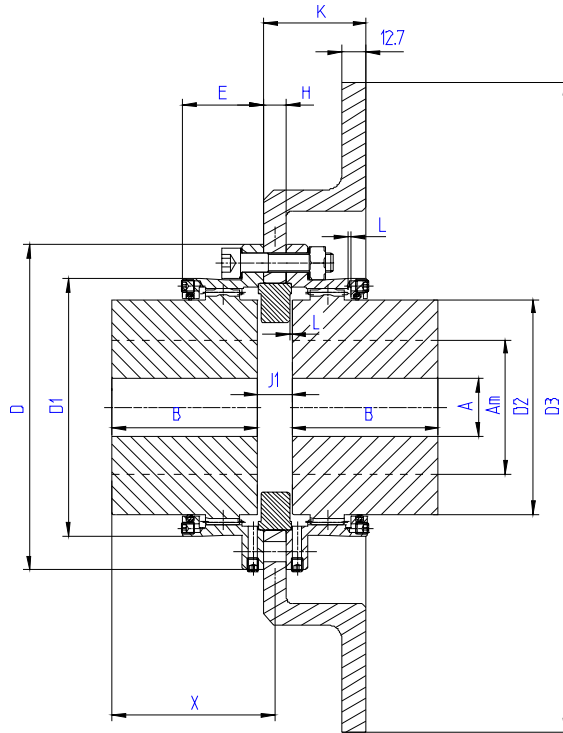

| Item | Designation |
|------|------------------------|
| 1 | Gear Hub |
| 2 | elbow shape brake disc |
| 3 | Centering ring |
| 4 | Half cover |
| 5 | Screws & Bolts |
| 6 | Seal |

| Brake disc dimensions | | | | | | | | | | |
|-----------------------|-----|-----|------|------|------|------|-----|------|------|-------|
| D3 | 250 | 305 | 355 | 406 | 457 | 515 | 610 | 711 | 812 | 914 |
| H | 6 | 13 | 16 | 13 | 16 | 16 | 16 | 19 | 25 | 25 |
| K | 36 | 41 | 54 | | | | | | | |
| Weight (kg) | 4 | 7.3 | 10.9 | 14.1 | 19.1 | 22.7 | 33 | 52.3 | 85.5 | 110.9 |

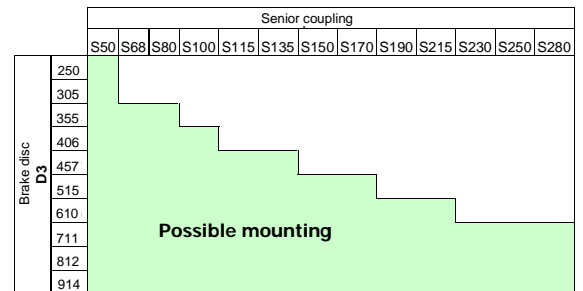

| Size | | 50 | 68 | 80 | 100 | 115 | 135 | 150 | 170 | 190 | 215 | 230 | 250 | 280 | |
|-----------------------|------------------|----------------|-------|-------|-------|-------|-------|-------|-------|-------|-------|--------|--------|--------|--|
| Nominal Torque | Nm | 1200 | 3000 | 5200 | 9000 | 13700 | 21300 | 29200 | 43000 | 60700 | 88200 | 105000 | 138000 | 190000 | |
| Max Bore | Am* | 50 | 68 | 80 | 100 | 115 | 135 | 150 | 170 | 190 | 215 | 230 | 250 | 280 | |
| | Am** | 46 | 63 | 75 | 92 | 106 | 125 | 140 | 160 | 175 | 200 | 210 | 230 | 250 | |
| Rough bore | A | 18 | 18 | 26 | 35 | 35 | 58 | 68 | 83 | 98 | 108 | 118 | 128 | 128 | |
| | B | 43 | 50 | 62 | 76 | 90 | 105 | 120 | 135 | 150 | 175 | 190 | 220 | 310 | |
| | D | 105 | 140 | 169 | 200 | 228 | 266 | 298 | 330 | 368 | 410 | 440 | 473 | 498 | |
| | D1 | 83.6 | 112.6 | 134 | 164 | 188 | 219 | 245 | 277 | 309 | 351 | 374 | 407 | 432 | |
| | D2 | 69.4 | 95 | 112 | 138 | 159 | 188 | 209 | 238 | 263 | 302 | 319 | 349 | 374 | |
| | E | 30.5 | 36 | 42 | 52 | 63.5 | 74 | 82 | 91 | 100 | 101.5 | 122 | 135.5 | 139 | |
| | J1 | J1 = H + 2 L | | | | | | | | | | | | | |
| | L | 1.3 | 1.5 | 2 | 2.5 | 2.8 | 3.2 | 3.5 | 4 | 4.5 | 5 | 5 | 5.8 | 7.3 | |
| | X | X = B + (J1/2) | | | | | | | | | | | | | |
| Weight • | Kg | 3.7 | 7.7 | 13.2 | 23.5 | 36.7 | 59 | 84 | 119 | 164 | 243 | 300 | 406 | 616 | |
| Moment of Inertia J • | Kgm ² | 0.004 | 0.012 | 0.030 | 0.079 | 0.166 | 0.368 | 0.649 | 1.141 | 1.962 | 3.63 | 5.08 | 8.08 | 13.07 | |
| | | 5400 | 4000 | 3400 | 2700 | 2400 | 2000 | 1800 | 1600 | 1500 | 1300 | 1200 | 1100 | 1000 | |
| Max speed (rpm) | y | 14000 | 10500 | 8900 | 7200 | 6300 | 5400 | 4800 | 4200 | 3800 | 3300 | 3100 | 2900 | 2700 | |
| | | 14000 | 10500 | 8900 | 7200 | 6300 | 5400 | 4800 | 4200 | 3800 | 3300 | 3100 | 2900 | 2700 | |
| Weight of grease ▽ | Kg | 0.04 | 0.08 | 0.12 | 0.26 | 0.38 | 0.6 | 0.8 | 1 | 1.7 | 2.2 | 2.9 | 3.8 | 4 | |

* Bore with keyway according ISO R 773 or DIN 6885/1 standard
 ** Shrink fitting
 • Solid hubs without brake disc
 y Dynamically balanced
 ▽ Per coupling

Type SBM – Horizontal working position

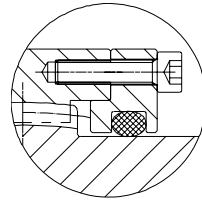
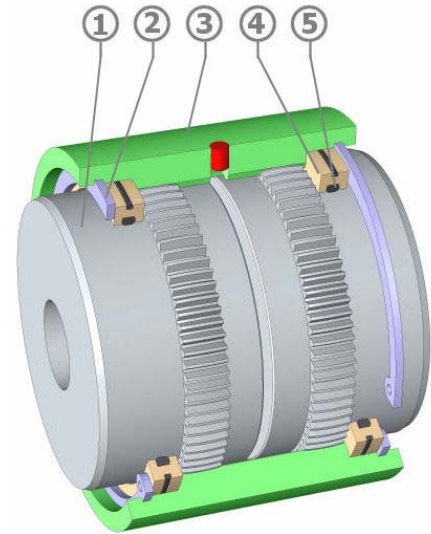
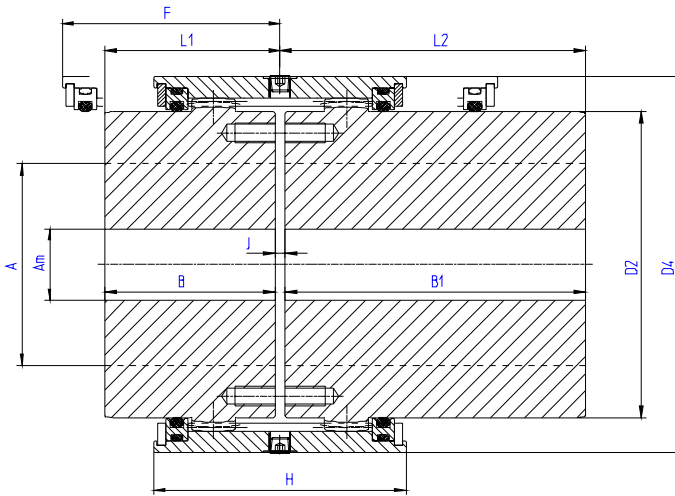

For sizes 215 up to 280

| Item | Designation |
|------|------------------|
| 1 | Gear Hub |
| 2 | Stop ring |
| 3 | Solid gear cover |
| 4 | flange |
| 5 | Seal |

Example of designation: **SBM80**
SENIOR coupling size **80** with solid gear cover.

| Size | | 50 | 68 | 80 | 100 | 115 | 135 | 150 | 170 | 190 | 215 | 230 | 250 | 280 |
|---|-------|-------|-------|-------|-------|-------|-------|-------|-------|-------|-------|--------|--------|--------|
| Nominal Torque | Nm | 1200 | 3000 | 5200 | 9000 | 13700 | 21300 | 29200 | 43000 | 60700 | 88200 | 105000 | 138000 | 190000 |
| Max Bore | Am* | 50 | 68 | 80 | 100 | 115 | 135 | 150 | 170 | 190 | 215 | 230 | 250 | 280 |
| | Am** | 46 | 63 | 75 | 92 | 106 | 125 | 140 | 160 | 175 | 200 | 210 | 230 | 250 |
| Rough bore | A | 18 | 18 | 26 | 35 | 35 | 58 | 68 | 83 | 98 | 108 | 118 | 128 | 128 |
| | B | 43 | 50 | 62 | 76 | 90 | 105 | 120 | 135 | 150 | 175 | 190 | 220 | 310 |
| | B1 | 105 | 115 | 130 | 150 | 170 | 185 | 215 | 245 | 295 | 300 | 305 | 350 | - |
| | D2 | 69.4 | 95 | 112 | 138 | 159 | 188 | 209 | 238 | 263 | 302 | 319 | 349 | 374 |
| | D4 | 95 | 125 | 144 | 177 | 204 | 246 | 265 | 292 | 324 | 360 | 383 | 417 | 442 |
| | L1 | 44.5 | 51.5 | 63.5 | 78.5 | 92.5 | 108 | 123 | 139 | 154 | 179 | 194 | 225 | - |
| | L2 | 106.5 | 116.5 | 131.5 | 152.5 | 172.5 | 188 | 218 | 249 | 299 | 304 | 309 | 355 | - |
| | J | 3 | 3 | 3 | 5 | 5 | 6 | 6 | 8 | 8 | 8 | 8 | 10 | 10 |
| | F | 63 | 72 | 86 | 104 | 122 | 145 | 161 | 177 | 193 | 199 | 219 | 252 | 342 |
| | H | 78 | 92 | 106 | 128 | 152 | 181 | 198 | 216 | 234 | 195 | 218 | 245 | 252 |
| Weight (Kg) • | SBM | 3.9 | 8.3 | 13.6 | 24.9 | 39.5 | 67 | 88.5 | 122.5 | 165 | 237.6 | 287.7 | 394.3 | 605.3 |
| | SBML | 5.8 | 11.9 | 18.9 | 33.5 | 51.8 | 84.2 | 114 | 160.6 | 226.6 | 307.4 | 359.5 | 491.6 | - |
| | SBML2 | 7.6 | 15.5 | 24.1 | 42.2 | 64.1 | 101.5 | 139.5 | 198.7 | 288.2 | 377.1 | 431.4 | 588.8 | - |
| Moment of Inertia J • (Kgm ²) | SBM | 0.004 | 0.015 | 0.032 | 0.09 | 0.19 | 0.47 | 0.71 | 1.18 | 1.95 | 2.85 | 3.86 | 6.31 | 10.94 |
| | SBML | 0.075 | 0.12 | 0.16 | 0.26 | 0.41 | 0.78 | 1.15 | 1.86 | 3.03 | 4.54 | 5.87 | 9.49 | - |
| | SBML2 | 0.15 | 0.22 | 0.28 | 0.43 | 0.63 | 1.10 | 1.59 | 2.54 | 4.1 | 6.22 | 7.87 | 12.66 | - |
| Max speed (rpm) | | 5400 | 4000 | 3400 | 2700 | 2400 | 2000 | 1800 | 1600 | 1500 | 1300 | 1200 | 1100 | 1000 |
| | y | 14000 | 10500 | 8900 | 7200 | 6300 | 5400 | 4800 | 4200 | 3800 | 3300 | 3100 | 2900 | 2700 |
| Weight of grease ∇ | Kg | 0.04 | 0.08 | 0.12 | 0.26 | 0.38 | 0.6 | 0.8 | 1 | 1.7 | 2.2 | 2.9 | 3.8 | 4 |

* Bore with keyway according ISO R 773 or DIN 6885/1 standard
 ** Shrink fitting
 • Solid hubs
 y Dynamically balanced
 ∇ Per coupling

Type SBM – Horizontal working position

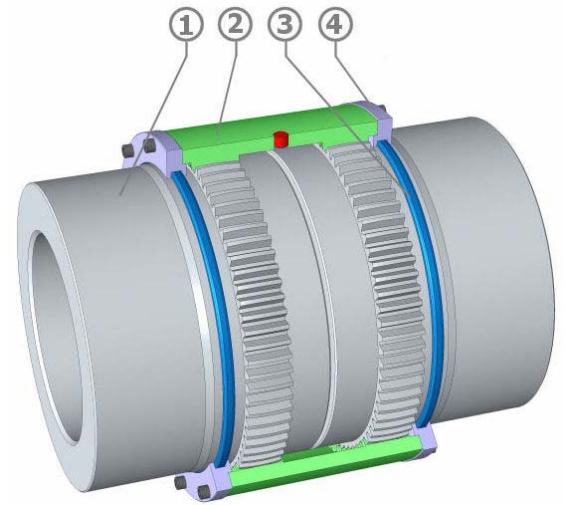
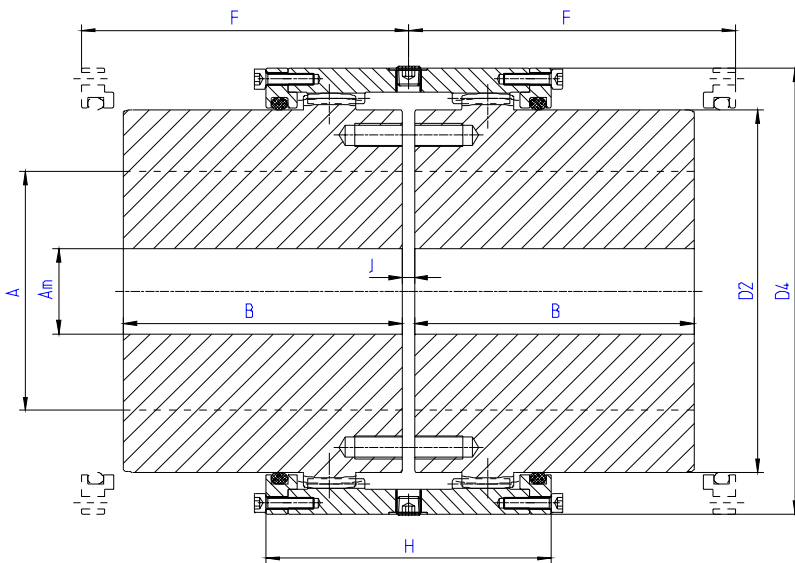

| Item | Designation |
|------|------------------|
| 1 | Gear Hub |
| 2 | Solid gear cover |
| 3 | Seal |
| 4 | Flange |

Example of designation: SBM310
SENIOR coupling size 310 with solid gear cover.

| Size | | 310 | 330 | 370 | 400 | 430 | 475 | 510 | 550 | 610 | 650 | 710 | 750 | 800 | |
|--------------------|--------------------|------------------------|---------------|---------------|---------------|---------------|---------------|----------------|----------------|----------------|----------------|----------------|----------------|----------------|--------|
| Nominal Torque | Nm | 255000 | 320000 | 410000 | 525000 | 670000 | 850000 | 1100000 | 1400000 | 1800000 | 2400000 | 3200000 | 3750000 | 4950000 | |
| Max Bore | Am* | 310 | 330 | 370 | 400 | 430 | 475 | 510 | 550 | 610 | 650 | 710 | 750 | 800 | |
| | Am** | 310 | 330 | 370 | 400 | 430 | 475 | 510 | 550 | 610 | 650 | 710 | 750 | 800 | |
| Rough bore | A | 163 | 176 | 191 | 240 | 257 | 279 | 304 | 329 | 358 | 394 | 434 | 457 | 501 | |
| | B | 310 | 330 | 350 | 370 | 430 | 480 | 505 | 515 | 535 | 575 | 610 | 650 | 700 | |
| | D2 | 411 | 438 | 492 | 535 | 581 | 645 | 700 | 770 | 835 | 890 | 975 | 1030 | 1095 | |
| | D4 | 494 | 518 | 576 | 637 | 695 | 785 | 840 | 910 | 1000 | 1060 | 1170 | 1225 | 1295 | |
| | J | 12 | 12 | 12 | 15 | 15 | 16 | 20 | 20 | 25 | 25 | 30 | 30 | 30 | |
| | F | 350 | 370 | 395 | 420 | 478 | 550 | 570 | 575 | 600 | 640 | 680 | 720 | 770 | |
| | H | 310 | 332 | 332 | 381 | 408 | 424 | 500 | 500 | 540 | 610 | 670 | 690 | 770 | |
| | Weight • | Kg | 761 | 908 | 1190 | 1531 | 2083 | 2882 | 3605 | 4372 | 5374 | 6559 | 8411 | 9867 | 12056 |
| | Moment d'Inerie J• | Kgm² | 18 | 24 | 39.3 | 60.8 | 97.1 | 167.3 | 244.1 | 353.9 | 520.3 | 719.5 | 1117.3 | 1447.5 | 1983.5 |
| Max speed (rpm) | | 903 | 857 | 760 | 696 | 643 | 573 | 542 | 495 | 446 | 418 | 377 | 358 | 341 | |
| | y | 2409 | 2285 | 2026 | 1857 | 1714 | 1528 | 1445 | 1320 | 1188 | 1114 | 1005 | 955 | 909 | |
| Weight of grease ∇ | Kg | 6.2 | 6.6 | 7.9 | 11 | 13.5 | 18.2 | 22.3 | 23.8 | 30.5 | 37.1 | 48.5 | 62.2 | 73.5 | |

* Bore with keyway according ISO R 773 or DIN 6885/1 standard
 ** Shrink fitting
 • Solid hubs
 y Dynamically balanced
 ∇ Per coupling

Type JL – Horizontal working position Limited end float model

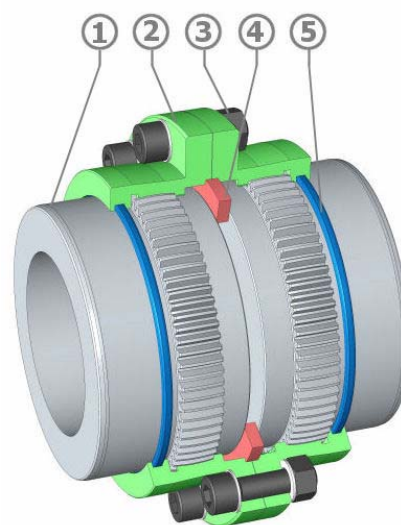
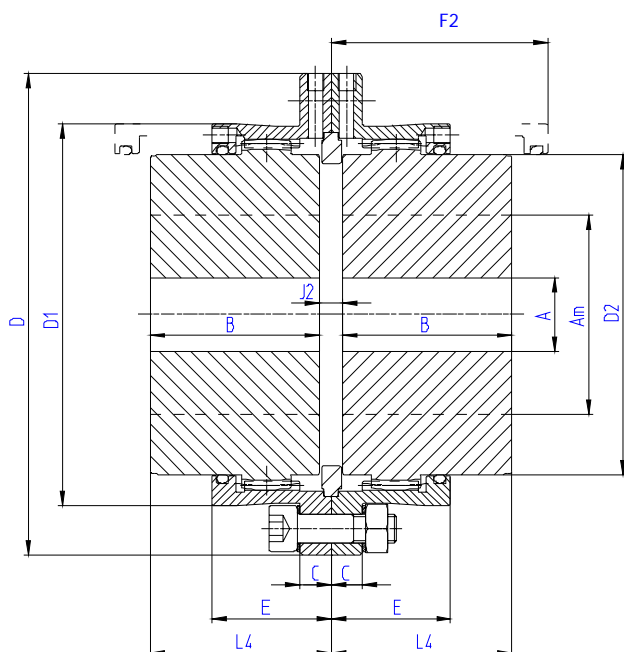

| Item | Designation |
|------|-------------------------|
| 1 | Gear Hub |
| 2 | Half cover |
| 3 | Screws & Bolts |
| 4 | Specific centering ring |
| 5 | Seal |

Example of designation: S 80 JL

SENIOR coupling size 80 whose axial clearance is reduced by a specific centering ring between the two hubs.
The misalignment capacities are reduced.

| Size | | 50 | 68 | 80 | 100 | 115 | 135 | 150 | 170 | 190 | 215 | 230 | 250 | 280 |
|----------------------|------------------------|-----------|-------|-------|-------|-------|-------|-------|-------|-------|-------|--------|--------|--------|
| Nominal Torque | Nm | 1200 | 3000 | 5200 | 9000 | 13700 | 21300 | 29200 | 43000 | 60700 | 88200 | 105000 | 138000 | 190000 |
| Max bore | Am* | 50 | 68 | 80 | 100 | 115 | 135 | 150 | 170 | 190 | 215 | 230 | 250 | 280 |
| | Am** | 46 | 63 | 75 | 92 | 106 | 125 | 140 | 160 | 175 | 200 | 210 | 230 | 250 |
| Rough bore | A | 18 | 18 | 26 | 35 | 35 | 58 | 68 | 83 | 98 | 108 | 118 | 128 | 128 |
| | B | 43 | 50 | 62 | 76 | 90 | 105 | 120 | 135 | 150 | 175 | 190 | 220 | 310 |
| | C | 10 | 10 | 11 | 11 | 14 | 18 | 20 | 20 | 24 | 24 | 30 | 30 | 30 |
| | D | 105 | 140 | 169 | 200 | 228 | 266 | 298 | 330 | 368 | 410 | 440 | 473 | 498 |
| | D1 | 83.6 | 112.6 | 134 | 164 | 188 | 219 | 245 | 277 | 309 | 351 | 374 | 407 | 432 |
| | D2 | 69.4 | 95 | 112 | 138 | 159 | 188 | 209 | 238 | 263 | 302 | 319 | 349 | 374 |
| | E | 30.5 | 36 | 42 | 52 | 63.5 | 74 | 82 | 91 | 100 | 110.5 | 122 | 135.5 | 139 |
| | J2 | 4.6 | 5.4 | 6 | 9 | 9.6 | 11.4 | 12 | 14 | 15 | 16 | 16.6 | 19.6 | 22.6 |
| GAP axial | +/- | 1 | 1 | 1 | 1 | 1 | 1 | 1 | 2 | 2 | 2 | 2 | 2 | 2 |
| | F2 | 57 | 65 | 78 | 97 | 117 | 135 | 150 | 170 | 190 | 215 | 230 | 263 | 355 |
| | L4 | 45.3 | 52.7 | 65 | 80.5 | 94.8 | 110.7 | 126 | 142 | 157.5 | 183 | 198.3 | 229.8 | 321.3 |
| | Weight • | Kg | 3.7 | 7.7 | 13.2 | 23.6 | 37 | 60 | 85 | 120 | 165 | 244 | 302 | 408 |
| Moment of Inertia J• | Kgm² | 0.004 | 0.012 | 0.030 | 0.080 | 0.167 | 0.371 | 0.655 | 1.151 | 1.978 | 3.66 | 5.22 | 8.14 | 13.16 |
| Max speed (rpm) | | 5400 | 4000 | 3400 | 2700 | 2400 | 2000 | 1800 | 1600 | 1500 | 1300 | 1200 | 1100 | 1000 |
| | y | 14000 | 10500 | 8900 | 7200 | 6300 | 5400 | 4800 | 4200 | 3800 | 3300 | 3100 | 2900 | 2700 |
| Weight of grease ∇ | Kg | 0.04 | 0.09 | 0.14 | 0.30 | 0.46 | 0.73 | 1 | 1.20 | 2 | 2.70 | 3.50 | 4.60 | 5 |

- * Bore with keyway according ISO R 773 or DIN 6885/1 standard
- ** Shrink fitting
- Solid hubs
- y Dynamically balanced
- ∇ Per coupling

Type ML – ML2 – Horizontal working position

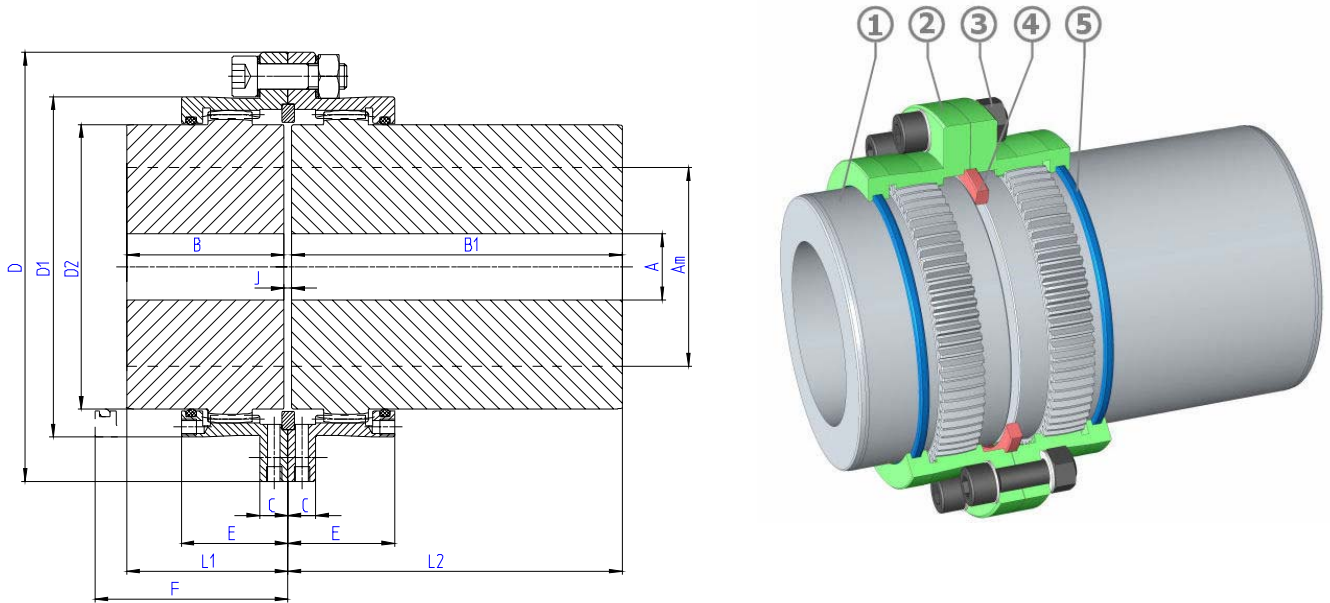

| Item | Designation |
|------|----------------|
| 1 | Gear Hub |
| 2 | Half cover |
| 3 | Screws & Bolts |
| 4 | Centering ring |
| 5 | Seal |

Example of designation: S 80 ML
SENIOR coupling size 80 with long hub.

| Size | | 50 | 68 | 80 | 100 | 115 | 135 | 150 | 170 | 190 | 215 | 230 | 250 | |
|--------------------|----------------------|-------|-------|-------|-------|-------|-------|-------|-------|-------|-------|--------|--------|------|
| Nominal Torque | Nm | 1200 | 3000 | 5200 | 9000 | 13700 | 21300 | 29200 | 43000 | 60700 | 88200 | 105000 | 138000 | |
| Max Bore | Am* | 50 | 68 | 80 | 100 | 115 | 135 | 150 | 170 | 190 | 215 | 230 | 250 | |
| | Am** | 46 | 63 | 75 | 92 | 106 | 125 | 140 | 160 | 175 | 200 | 210 | 230 | |
| Rough bore | A | 18 | 18 | 26 | 35 | 35 | 58 | 68 | 83 | 98 | 108 | 118 | 128 | |
| | B | 43 | 50 | 62 | 76 | 90 | 105 | 120 | 135 | 150 | 175 | 190 | 220 | |
| | B1 | 105 | 115 | 130 | 150 | 170 | 185 | 215 | 245 | 295 | 300 | 305 | 350 | |
| | C | 10 | 10 | 11 | 11 | 14 | 18 | 20 | 20 | 24 | 24 | 30 | 30 | |
| | D | 105 | 140 | 169 | 200 | 228 | 266 | 298 | 330 | 368 | 410 | 440 | 473 | |
| | D1 | 83.6 | 112.6 | 134 | 164 | 188 | 219 | 245 | 277 | 309 | 351 | 374 | 407 | |
| | D2 | 69.4 | 95 | 112 | 138 | 159 | 188 | 209 | 238 | 263 | 302 | 319 | 349 | |
| | E | 30.5 | 36 | 42 | 52 | 63.5 | 74 | 82 | 91 | 100 | 110.5 | 122 | 135.5 | |
| | J | 3 | 3 | 3 | 5 | 5 | 6 | 6 | 8 | 8 | 8 | 8 | 10 | |
| | F | 55 | 63 | 75 | 93 | 112 | 130 | 145 | 163 | 180 | 205 | 220 | 253 | |
| | L1 | 44.5 | 51.5 | 63.5 | 78.5 | 92.5 | 108 | 123 | 139 | 154 | 179 | 194 | 225 | |
| | F | 117 | 128 | 143 | 167 | 192 | 210 | 240 | 273 | 325 | 330 | 335 | 383 | |
| | L2 | 106.5 | 116.5 | 131.5 | 152.5 | 172.5 | 188 | 218 | 249 | 299 | 304 | 309 | 355 | |
| | Weight (Kg)• | SML | 5.5 | 11.2 | 18.4 | 32 | 49 | 77 | 110 | 157 | 226 | 313 | 373 | 503 |
| | | SML2 | 7.3 | 14.7 | 23.6 | 40.5 | 61.3 | 95 | 136 | 195 | 288 | 382 | 446 | 600 |
| | Moment of Inertia J• | SML | 0.005 | 0.016 | 0.038 | 0.099 | 0.204 | 0.443 | 0.785 | 1.407 | 2.485 | 4.42 | 6.08 | 9.54 |
| | | SML2 | 0.006 | 0.020 | 0.046 | 0.119 | 0.242 | 0.518 | 0.921 | 1.673 | 3.008 | 5.21 | 6.98 | 11 |
| | Max speed (rpm) | y | 5400 | 4000 | 3400 | 2700 | 2400 | 2000 | 1800 | 1600 | 1500 | 1300 | 1200 | 1100 |
| y | | 14000 | 10500 | 8900 | 7200 | 6300 | 5400 | 4800 | 4200 | 3800 | 3300 | 3100 | 2900 | |
| Weight of grease ∇ | Kg | 0.04 | 0.08 | 0.12 | 0.26 | 0.38 | 0.60 | 0.80 | 1 | 1.70 | 2.20 | 2.90 | 3.80 | |

- * Bore with keyway according ISO R 773 or DIN 6885/1 standard
- ** Shrink fitting
- Solid hubs
- y Dynamically balanced
- ∇ Per coupling

Type V – Vertical working position

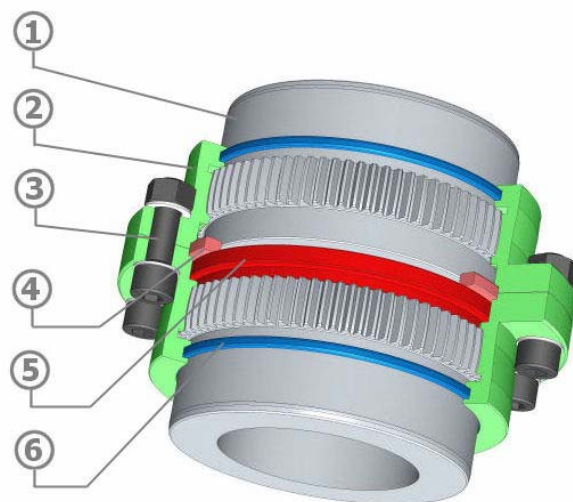
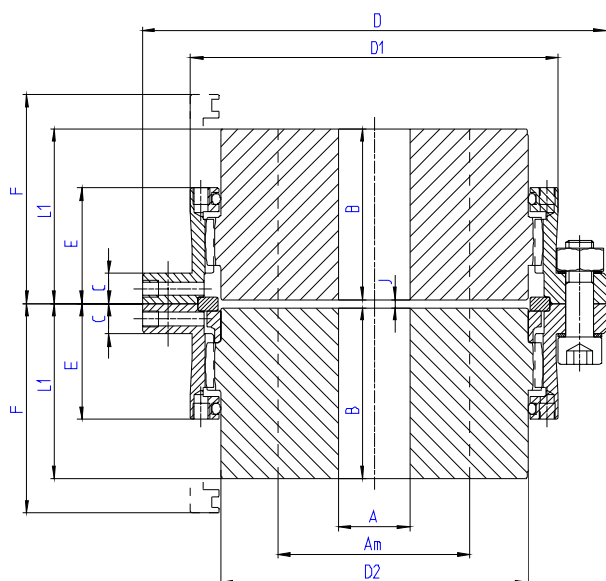

| Item | Designation |
|------|----------------|
| 1 | Gear Hub |
| 2 | Half cover |
| 3 | Screws & Bolts |
| 4 | Centering ring |
| 5 | Vertical ring |
| 6 | Seal |

Example of designation: S 80 V

SENIOR coupling size **80** which includes a vertical ring to maintain the position of the hub in vertical running.

This ring is available for all the models.

Ex : S 80 E 1000 V, 2 S 80 PA 1000 In. V

| Size | | 50 | 68 | 80 | 100 | 115 | 135 | 150 | 170 | 190 | 215 | 230 | 250 | 280 | |
|--------------------|----------------------|------------------------|-------------|-------------|-------------|--------------|--------------|--------------|--------------|--------------|--------------|---------------|---------------|---------------|-------|
| Nominal Torque | Nm | 1200 | 3000 | 5200 | 9000 | 13700 | 21300 | 29200 | 43000 | 60700 | 88200 | 105000 | 138000 | 190000 | |
| Max bore | Am* | 50 | 68 | 80 | 100 | 115 | 135 | 150 | 170 | 190 | 215 | 230 | 250 | 280 | |
| | Am** | 46 | 63 | 75 | 92 | 106 | 125 | 140 | 160 | 175 | 200 | 210 | 230 | 250 | |
| Rough bore | A | 18 | 18 | 26 | 35 | 35 | 58 | 68 | 83 | 98 | 108 | 118 | 128 | 128 | |
| | B | 43 | 50 | 62 | 76 | 90 | 105 | 120 | 135 | 150 | 175 | 190 | 220 | 310 | |
| | C | 10 | 10 | 11 | 11 | 14 | 18 | 20 | 20 | 24 | 24 | 30 | 30 | 30 | |
| | D | 105 | 140 | 169 | 200 | 228 | 266 | 298 | 330 | 368 | 410 | 440 | 473 | 498 | |
| | D1 | 83.6 | 112.6 | 134 | 164 | 188 | 219 | 245 | 277 | 309 | 351 | 374 | 407 | 432 | |
| | D2 | 69.4 | 95 | 112 | 138 | 159 | 188 | 209 | 238 | 263 | 302 | 319 | 349 | 374 | |
| | E | 30.5 | 36 | 42 | 52 | 63.5 | 74 | 82 | 91 | 100 | 110.5 | 122 | 135.5 | 139 | |
| | J | 3 | 3 | 3 | 5 | 5 | 6 | 6 | 8 | 8 | 8 | 8 | 10 | 10 | |
| | F | 55 | 63 | 75 | 93 | 112 | 130 | 145 | 163 | 180 | 205 | 220 | 253 | 343 | |
| | L1 | 44.5 | 51.5 | 63.5 | 78.5 | 92.5 | 108 | 123 | 139 | 154 | 179 | 194 | 225 | 315 | |
| | Weight • | Kg | 3.7 | 7.7 | 13.3 | 23.7 | 37 | 60 | 85 | 121 | 166 | 245 | 304 | 410 | 621 |
| | Moment of Inertia J• | Kgm² | 0.004 | 0.012 | 0.030 | 0.08 | 0.169 | 0.374 | 0.659 | 1.161 | 1.997 | 3.69 | 5.28 | 8.23 | 13.26 |
| Max speed (rpm) | | 5400 | 4000 | 3400 | 2700 | 2400 | 2000 | 1800 | 1600 | 1500 | 1300 | 1200 | 1100 | 1000 | |
| | y | 14000 | 10500 | 8900 | 7200 | 6300 | 5400 | 4800 | 4200 | 3800 | 3300 | 3100 | 2900 | 2700 | |
| Weight of grease ∇ | kg | 0.03 | 0.07 | 0.10 | 0.22 | 0.34 | 0.50 | 0.70 | 0.90 | 1.40 | 1.90 | 2.50 | 3.20 | 3.4 | |

* Bore with keyway according ISO R 773 or DIN 6885/1 standard

** Shrink fitting

• Solid hubs

y Dynamically balanced

∇ Per coupling

Type SDB – Horizontal working position

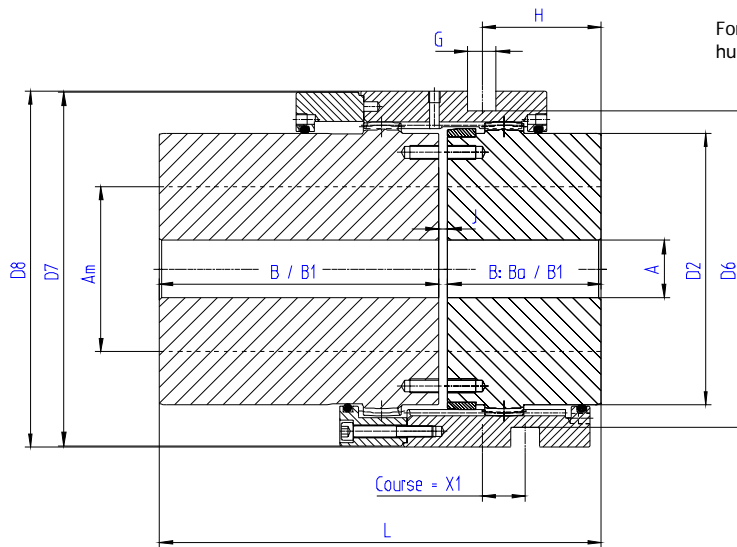

For sizes 50 & 68, the long hub is by this side

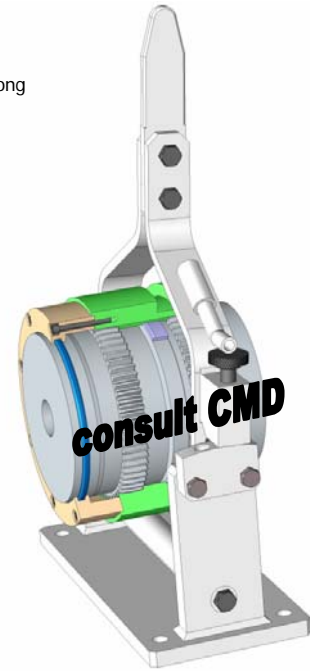

Example of designation : S 80 MLDB

SENIOR clutch coupling size 80 with one long hub.

| Size | | Manual | | With acting system | | | | | | | | | | |
|----------------------|----------|---------|-----------|--------------------|-------|-------|-------|-------|-------|-------|-------|--------|--------|-----|
| | | 50 | 68 | 80 | 100 | 115 | 135 | 150 | 170 | 190 | 215 | 230 | 250 | |
| Nominal Torque | Nm | 1200 | 3000 | 5200 | 9000 | 13700 | 21300 | 29200 | 43000 | 60700 | 88200 | 105000 | 138000 | |
| Max Bore | Am* | 50 | 68 | 80 | 100 | 115 | 135 | 150 | 170 | 190 | 215 | 230 | 250 | |
| | Am** | 46 | 63 | 75 | 92 | 106 | 125 | 140 | 160 | 175 | 200 | 210 | 230 | |
| Rough bore | A | 18 | 18 | 26 | 35 | 35 | 58 | 68 | 83 | 98 | 108 | 118 | 128 | |
| | B : Ba | 43 : 62 | 50 : 72 | 62 | 76 | 90 | 105 | 120 | 135 | 150 | 175 | 190 | 220 | |
| | B1 | 105 | 115 | 130 | 150 | 170 | 185 | 215 | 245 | 295 | 300 | 305 | 350 | |
| | D2 | 69,4 | 95 | 112 | 138 | 159 | 188 | 209 | 238 | 263 | 302 | 319 | 349 | |
| | D6 | / | / | 132 | 164 | 189 | 222 | 246 | 278 | 312 | 353 | 376 | 406 | |
| | D7 | 100 | 128 | 148 | 190 | 210 | 240 | 270 | 310 | 330 | 390 | 10 | 440 | |
| | D8 | 102 | 130 | 148 | 188 | 213 | 246 | 280 | 312 | 346 | 397 | 420 | 450 | |
| | G | / | / | 12 | 18 | 18 | 18 | 25 | 25 | 25 | 32 | 32 | 32 | |
| | H | / | / | 50 | 60 | 70 | 82 | 90 | 105 | 115 | 135 | 145 | 170 | |
| | J | 3 | 3 | 3 | 5 | 5 | 6 | 6 | 8 | 8 | 8 | 8 | 10 | |
| | X1 | 11 | 14 | 19 | 22 | 25 | 29 | 32 | 38 | 40 | 48 | 50 | 55 | |
| Models | S..DB | L | 108 | 125 | 127 | 157 | 185 | 216 | 246 | 278 | 308 | 358 | 388 | 450 |
| | S..MLDB | L | 151 : 170 | 168 : 190 | 195 | 231 | 265 | 296 | 341 | 388 | 453 | 483 | 503 | 580 |
| | S..ML2DB | L | 213 | 233 | 263 | 305 | 345 | 376 | 436 | 498 | 598 | 608 | 618 | 710 |
| Weight (Kg)• | S..DB | - | - | 14.4 | 26.1 | 43.5 | 68.1 | 97 | 138.7 | 185 | | | | |
| | S..MLDB | - | - | 19.7 | 34.7 | 55.9 | 85.5 | 122.5 | 177 | 246.6 | | | | |
| | S..ML2DB | - | - | 25 | 43.8 | 68.3 | 102.9 | 148 | 215.6 | 308.2 | | | | |
| Moment of Inertia J• | S..DB | - | - | 0.036 | 0.108 | 0.227 | 0.489 | 0.854 | 1.540 | 2.469 | | | | |
| | S..MLDB | - | - | 0.044 | 0.128 | 0.366 | 0.565 | 0.993 | 1.810 | 3.001 | | | | |
| | S..ML2DB | | | 0.052 | 0.196 | 0.405 | 0.641 | 1.132 | 2.082 | 3.533 | | | | |
| Max speed (rpm) | Ω | 2500 | 2000 | 1300 | 1100 | 890 | 780 | 680 | 610 | 550 | 480 | 450 | 420 | |
| Weight of grease ▽ | Kg | 0.04 | 0.08 | 0.12 | 0.26 | 0.38 | 0.60 | 0.80 | 1 | 1.70 | 2.20 | 2.90 | 3.80 | |

- * Bore with keyway according ISO R 773 or DIN 6885/1 standard
- ** Shrink fitting
- Solid hubs
- Ω for higher speed, please consult us
- ▽ Per coupling

Type SR – Horizontal working position

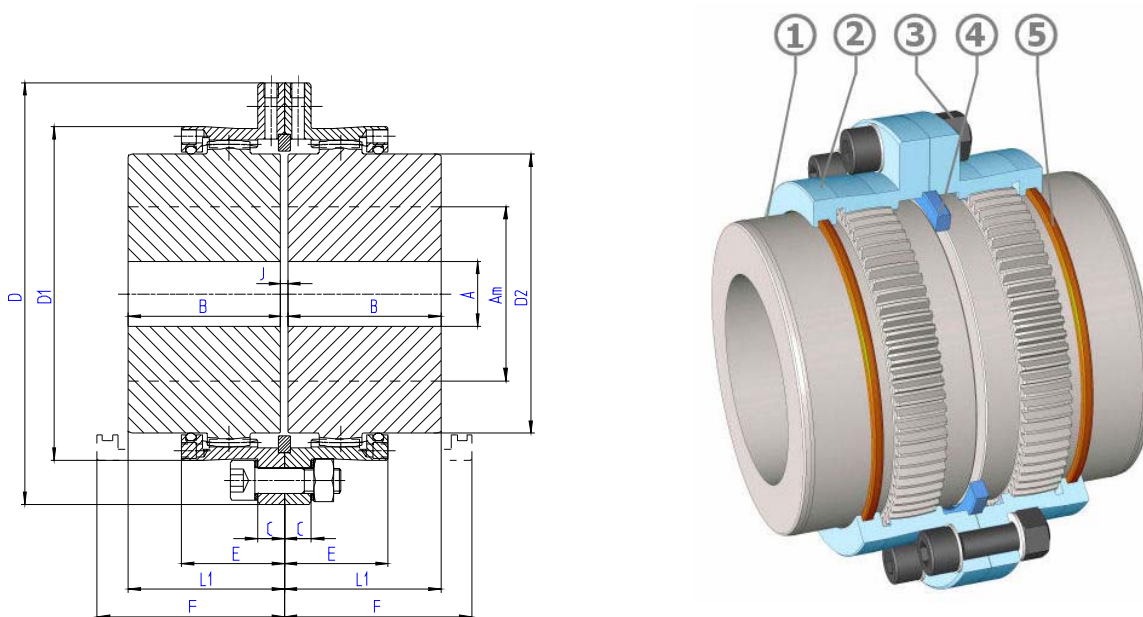

| Item | Designation |
|------|----------------|
| 1 | Gear Hub |
| 2 | Half cover |
| 3 | Screws & Bolts |
| 4 | Centering ring |
| 5 | Seal |

Example of designation: S80R
SENIOR coupling Reinforced (42 CrMo4) size 80.

| Size | | 50 | 68 | 80 | 100 | 115 | 135 | 150 | 170 | 190 | 215 | 230 | 250 | 280 |
|-----------------------|------------------|-------|-------|-------|-------|-------|-------|-------|-------|-------|--------|--------|--------|--------|
| Nominal Torque | Nm | 1855 | 4570 | 7910 | 13635 | 20740 | 32220 | 44000 | 65110 | 91865 | 133490 | 159160 | 207000 | 302450 |
| Max Bore | Am* | 50 | 68 | 80 | 100 | 115 | 135 | 150 | 170 | 190 | 215 | 230 | 250 | 280 |
| | Am** | 46 | 63 | 75 | 92 | 106 | 125 | 140 | 160 | 175 | 200 | 210 | 230 | 250 |
| Rough bore | A | 18 | 18 | 26 | 35 | 35 | 58 | 68 | 83 | 98 | 108 | 118 | 128 | 128 |
| | B | 43 | 50 | 62 | 76 | 90 | 105 | 120 | 135 | 150 | 175 | 190 | 220 | 310 |
| | C | 10 | 10 | 11 | 11 | 14 | 18 | 20 | 20 | 24 | 24 | 30 | 30 | 30 |
| | D | 105 | 140 | 169 | 200 | 228 | 266 | 298 | 330 | 368 | 410 | 440 | 473 | 498 |
| | D1 | 83.6 | 112.6 | 134 | 164 | 188 | 219 | 245 | 277 | 309 | 351 | 374 | 407 | 432 |
| | D2 | 69.4 | 95 | 112 | 138 | 159 | 188 | 209 | 238 | 263 | 302 | 319 | 349 | 374 |
| | E | 30.5 | 36 | 42 | 52 | 63.5 | 74 | 82 | 91 | 100 | 110.5 | 122 | 135.5 | 139 |
| | J | 3 | 3 | 3 | 5 | 5 | 6 | 6 | 8 | 8 | 8 | 8 | 10 | 10 |
| | F | 55 | 63 | 75 | 93 | 112 | 130 | 145 | 163 | 180 | 205 | 220 | 253 | 343 |
| | L1 | 44.5 | 51.5 | 63.5 | 78.5 | 92.5 | 108 | 123 | 139 | 154 | 179 | 194 | 225 | 315 |
| Weight • | Kg | 3.7 | 7.7 | 13.2 | 23.5 | 36.7 | 59 | 84 | 119 | 164 | 243 | 300 | 406 | 616 |
| Moment of Inertia J • | Kgm ² | 0.004 | 0.012 | 0.030 | 0.079 | 0.166 | 0.368 | 0.649 | 1.141 | 1.962 | 3.63 | 5.08 | 8.08 | 13.07 |
| Max speed (rpm) | | 5400 | 4000 | 3400 | 2700 | 2400 | 2000 | 1800 | 1600 | 1500 | 1300 | 1200 | 1100 | 1000 |
| | y | 14000 | 10500 | 8900 | 7200 | 6300 | 5400 | 4800 | 4200 | 3800 | 3300 | 3100 | 2900 | 2700 |
| Weight of grease ∇ | Kg | 0.04 | 0.08 | 0.12 | 0.26 | 0.38 | 0.6 | 0.8 | 1 | 1.7 | 2.2 | 2.9 | 3.8 | 4 |

- * Bore with keyway according ISO R 773 or DIN 6885/1 standard
- ** Shrink fitting
- Solid hubs
- y Dynamically balanced
- ∇ Per coupling

Type SR – Horizontal working position

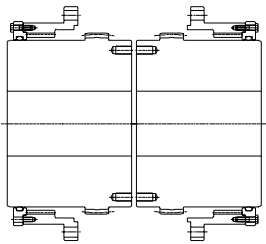
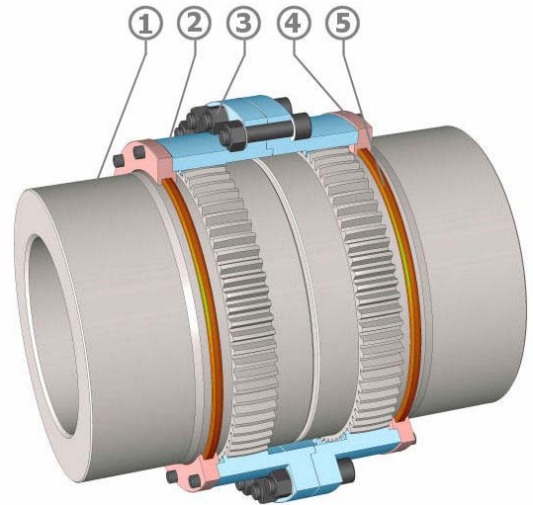
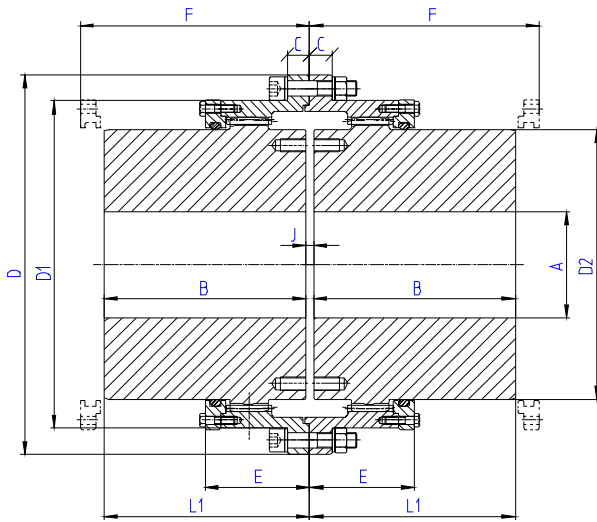

Inspection of the gear teeth is possible without having to remove the covers.

| Item | Designation |
|------|----------------|
| 1 | Gear Hub |
| 2 | Half cover |
| 3 | Screws & Bolts |
| 4 | Cover |
| 5 | Seal |

Example of designation: S310R
SENIOR coupling Reinforced (42 CrMo4) size 310.

| Size | | 310 | 330 | 370 | 400 | 430 | 475 | 510 | 550 | 610 | 650 | 710 | 750 | 800 |
|----------------------|-------------|---------------|---------------|---------------|---------------|----------------|----------------|----------------|----------------|----------------|----------------|----------------|----------------|----------------|
| Nominal Torque | Nm | 400000 | 500850 | 637500 | 848540 | 1078000 | 1356400 | 1714000 | 2211000 | 2830000 | 3770000 | 5000100 | 5890000 | 7780000 |
| Max Bore | Am* | 310 | 330 | 370 | 400 | 430 | 475 | 510 | 550 | 610 | 650 | 710 | 750 | 800 |
| | Am** | 310 | 330 | 370 | 400 | 430 | 475 | 510 | 550 | 610 | 650 | 710 | 750 | 800 |
| Rough bore | A | 163 | 176 | 191 | 240 | 257 | 279 | 304 | 329 | 358 | 394 | 434 | 457 | 501 |
| | B | 310 | 330 | 350 | 370 | 430 | 480 | 505 | 515 | 535 | 575 | 610 | 650 | 700 |
| | C | 34 | 34 | 39 | 43 | 47 | 56 | 56 | 55 | 65 | 70 | 70 | 70 | 75 |
| | D | 575 | 608 | 676 | 735 | 793 | 940 | 990 | 1100 | 1225 | 1285 | 1395 | 1450 | 1555 |
| | D1 | 494 | 518 | 576 | 637 | 695 | 785 | 840 | 910 | 1000 | 1060 | 1170 | 1225 | 1295 |
| | D2 | 411 | 438 | 492 | 535 | 581 | 645 | 700 | 770 | 835 | 890 | 975 | 1030 | 1095 |
| | E | 155 | 166 | 166 | 190.5 | 204 | 212 | 250 | 250 | 270 | 305 | 335 | 345 | 385 |
| | J | 12 | 12 | 12 | 15 | 15 | 16 | 20 | 20 | 25 | 25 | 30 | 30 | 30 |
| | F | 350 | 370 | 395 | 420 | 478 | 550 | 570 | 575 | 600 | 640 | 680 | 720 | 770 |
| | L1 | 316 | 336 | 356 | 377.5 | 437.5 | 488 | 515 | 525 | 547.5 | 587.5 | 625 | 665 | 715 |
| Weight • | Kg | 805 | 957 | 1261 | 1613 | 2191 | 3091 | 3825 | 4676 | 5833 | 7101 | 9025 | 10522 | 12927 |
| Moment of Inertia J• | Kgm² | 21.9 | 29.1 | 47.6 | 74.1 | 116.9 | 215.3 | 307.4 | 449.9 | 687.4 | 936 | 1419.4 | 1795.7 | 2512.1 |
| Max speed (rpm) | | 903 | 857 | 760 | 696 | 643 | 573 | 542 | 495 | 446 | 418 | 377 | 358 | 341 |
| | y | 2409 | 2285 | 2026 | 1857 | 1714 | 1528 | 1445 | 1320 | 1188 | 1114 | 1005 | 955 | 909 |
| Weight of grease ▽ | Kg | 6.2 | 6.6 | 7.9 | 11 | 13.5 | 18.2 | 22.3 | 23.8 | 30.5 | 37.1 | 48.5 | 62.2 | 73.5 |

- * Bore with keyway according ISO R 773 or DIN 6885/1 standard
- ** Shrink fitting
- Solid hubs
- y Dynamically balanced
- ▽ Per coupling

4 Reasons to choose Flexident Senior

1 High standards

Flexident Senior is a 100% steel coupling, manufactured with accuracy by CMD. Its components include two internally geared half covers, which are tightened together with a set of treated bolts. The half covers are then assembled onto two geared hubs. The teeth of the hubs and covers receive shape corrections, which are calculated and optimized by CMD to obtain maximum contact surface under load, and to allow the highest misalignment capacity.

2 Reliability

Flexident Senior couplings were designed by the CMD engineering department. Their specification was checked by the most elaborate finite elements software, and was further validated by the CMD running bench test.

3 Reactivity & short delivery time

FLEXIDENT SENIOR couplings are manufactured in serial production spare parts are stocked in the CMD warehouse, and in CMD distributors warehouses which are present all over the world.

4 Quality of Service

CMD has built an ISO 9001 organization inside the company, which reflects CMD's will to answer all requests from the customer:

Technical: CMD technicians and engineers can help you in selecting a standard CMD coupling or designing a specific coupling for your application. CMD design department is equipped with the latest CAD and finite elements software in order to validate new designs.

Validation: CMD test bench allows to run and test the behaviour and reliability of existing couplings or new developments. It allows to apply different load and misalignment conditions to these couplings.

Sales: A wide and worldwide network of distributors hold a stock of couplings and can assist you in the selection of the proper one. They are further supported everyday by CMD sales engineers.

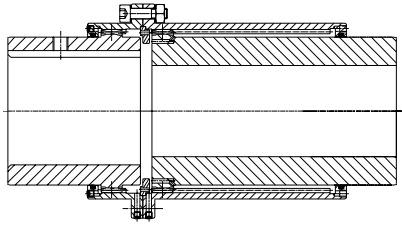
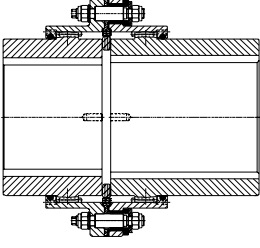
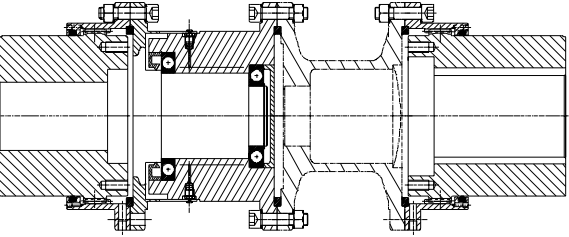
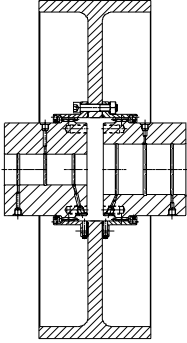
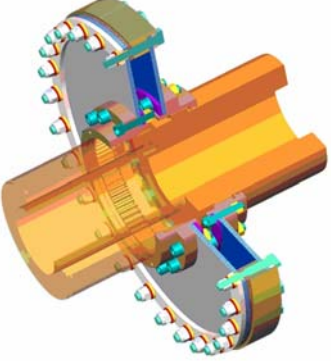
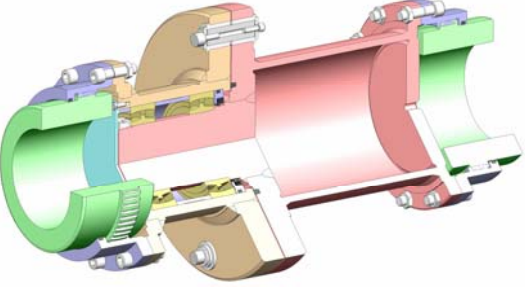
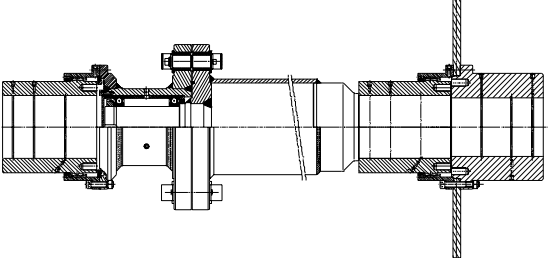
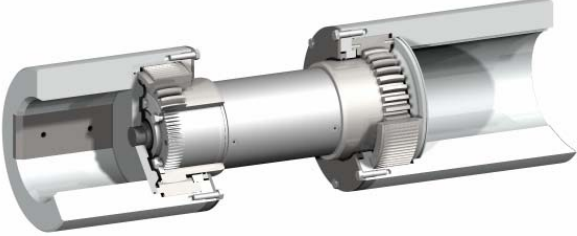

The CMD Coupling department can also design or modify couplings dedicated to specific applications. We are at your disposal for any requests, technical studies... Here there are some examples:

| | |
|---|--|
|  |  |
| <p align="center">Coupling with sliding hub</p> | <p align="center">Coupling electrically insulated</p> |
|  |  |
| <p align="center">Coupling with safeset</p> | <p align="center">Coupling with pulley brake</p> |
|  |  |
| <p align="center">Coupling with high axial misalignment</p> | <p align="center">Coupling with shear pins</p> |
|  |  |
| <p align="center">Coupling with spacer and shear pins brake disc</p> | <p align="center">Steel mill gear spindle</p> |

Other Products

Flexible couplings



Flexacier T



Winflex DG



Flexacier 9000



Tonoflex*

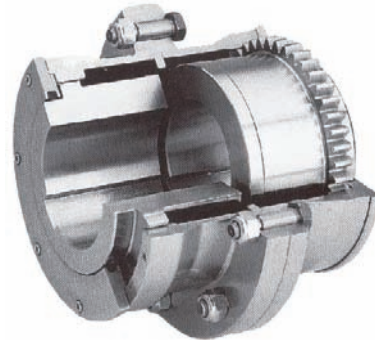

Flexident Z

* This product can only be supplied out of European Union when mounted on gearboxes.



SALES DEPARTMENT

36 avenue de l'Europe - Immeuble l'Etendard
BP 43 - 78142 VELIZY Cedex - FRANCE
Tél : +33(0) 1 34 63 12 24 - Fax : +33(0) 1 34 63 12 45
contact@cmdgears.com

HEAD OFFICE FACTORY

539, avenue du Cateau - 59400 CAMBRAI - FRANCE
Tél : +33(0) 3 27 73 53 11 - Fax : +33(0) 3 27 78 36 99
www.cmd-couplings.com
www.cmd-gears.com